

VECTRIX VX-2 SERVICE MANUAL



VECTRIX™

www.vectrix.com
service@vectrix.com



Version 1.0/July 2011
VECTRIX, LLC

VECTRIX VX-2 SERVICE MANUAL

CONTENTS

SECTION A: Tools

- 1 Tools Needed
- 2 VX-2 Major Components Identification

SECTION B: Mechanical Parts

- 1 Front Fairing
- 2 Front Console Cover/Wind Deflector
- 3 Speedometer Cover
- 4 Front Vertical Panel Cover-Lower
- 5 Front Vertical Panel Cover-Upper
- 6 Center Step-Through Cover
- 7 Front Fender
- 8 Seat
- 9 Under Board/Belly Pan
- 10 Foot Rest
- 11 Crossover/Tail Light Assembly
- 12 Rear Side Body Panels/Side Emblem
- 13 Rear Fender-Top
- 14 Side Cover/Swing Arm Cover
- 15 Front Wheel
- 16 Front Brake Master Cylinder/Line/Caliper
- 17 Rear Brake Master Cylinder/Line/Caliper
- 18 Rear Shock
- 19 Rear Swing Arm/Motor Assembly
- 20 Handlebar

SECTION C: Electrical Parts

- 1 Speedometer
- 2 Throttle
- 3 Brake Switch
- 4 Handlebar-Left Switch Assembly
- 5 Handlebar-Right Switch Assembly
- 6 Ignition Switch
- 7 Horn
- 8 Position Light/Headlamp Assembly
- 9 Front Turn Indicator Assembly
- 10 Side Stand Switch
- 11 Rear Tail Light Assembly
- 12 License Plate Light Assembly
- 13 Rear Turn Indicator Light Assembly
- 14 Motor Controller
- 15 Motor
- 16 Battery
- 17 Battery Charger

VECTRIX VX-2 SERVICE MANUAL

SECTION D: Adjustments

- 1 Front Headlamp/Position Light Adjustment

SECTION E: Troubleshooting

- 1 Indication on Speedometer Display & Controller LED
- 2 Malfunctions
- 3 Check of Charger Function

SECTION F: Technical Information

- 1 Cable Assembly-Front Brake/Turn Indicators + BOM
- 2 Cable Assembly-Front Headlamp/Horn + BOM
- 3 Cable Assembly-Rear Brake/Indicators/Tail Light/Battery/Side Stand + BOM
- 4 Torque List for Bolts/Nuts

SECTION G: Unpacking/Prep

- 1 Unpacking Instructions

VECTRIX VX-2 SERVICE MANUAL

SECTION A-1: TOOLS NEEDED

For repairing and testing of the VX-2 scooter the following tools are needed:

Tools:

Description	Specification
Open wrench	5.5mm
Open wrench/Turned Full-contact (#S02445)	8mm
Open wrench	10mm
Open wrench	12mm
Open wrench	13mm
Open wrench	14mm
Open wrench	16mm
Open wrench	17mm
Open wrench	18mm
Open wrench	19mm
Open wrench	32mm
Open wrench	45mm
Special tool/Motor Nut (contact service@vectrix.com)	42mm spanner socket with 22mm relief slot
	
Torque wrench	0-20Nm
Torque wrench	10-100Nm
Spanner socket	12mm
Spanner socket	13mm
Spanner socket	14mm
Spanner socket	17mm
Allen key	2.5mm
Allen key	4mm
Allen key	5mm
Allen key	6mm
Phillips screwdriver	#1
Phillips screwdriver	#2
Phillips screwdriver	#3
Screwdriver, flat	4.5mm
Screwdriver, flat	9mm
Security TORX Screwdriver	TX10

VECTRIX VX-2 SERVICE MANUAL

SECTION A-2: VX-2 MAJOR COMPONENTS IDENTIFICATION

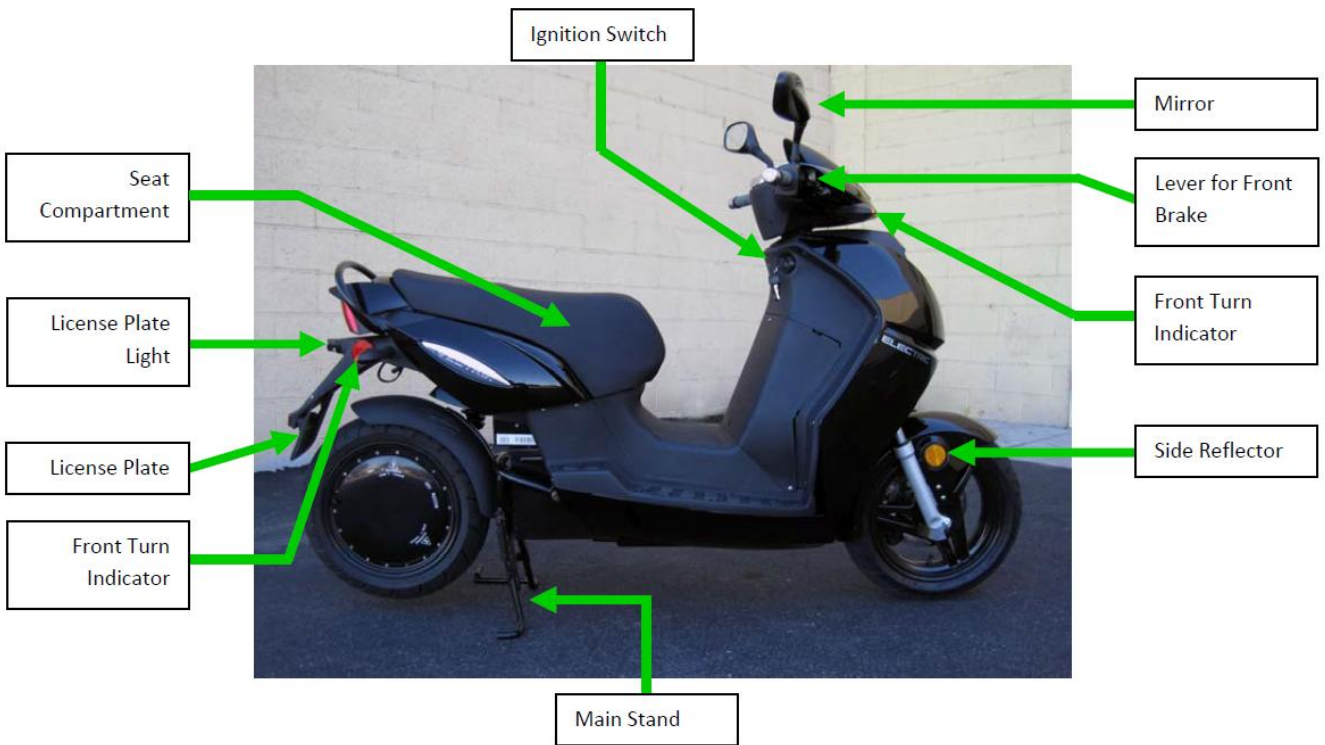

VECTRIX VX-2 SERVICE MANUAL

SECTION B

The following SECTION B instructions are for the VX-2 MECHANICAL disassembly/assembly. Unless otherwise noted in each procedure, assemble all parts in the reverse order in which they were taken apart. If you have any questions regarding VX-2 Mechanical disassembly/assembly procedures, please contact service@vectrix.com.

VECTRIX VX-2 SERVICE MANUAL

SECTION B-1: FRONT FAIRING

To protect the front fender, put plastic wrap or other soft material onto the fender



Unscrew the 6 Phillips screws 1 to 6 in order as seen in the picture with a Phillips screwdriver PH2

Remark:

While loosening screws 7 and 8 hold the front fairing otherwise it drops down and could break!

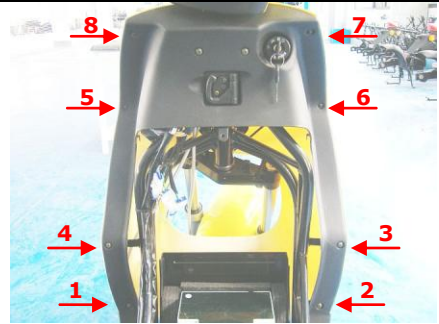

Remark:

While loosening screws 7 and 8 hold the front fairing otherwise it drops down and could break!

To unplug the headlight assembly, hold the front fairing and loosen all the connectors of the headlight

To reassemble after unplugging the headlight assembly, please be sure the clamp nuts are in the correct position



Remark:

For assembling the Front Fairing, please make sure the attachment points are in the right position and no edge is protruding. Insert the screws slightly and if all screws and the fairing are in the correct positions, then tighten them fully.

See also the last picture in the next Section for the correct position of the clamp screw.

VECTRIX VX-2 SERVICE MANUAL

SECTION B-2: FRONT CONSOLE COVER/WIND DEFLECTOR

Locate four Phillips screws underneath the Front Console Cover/Wind Deflector and remove



Slide in a flat screwdriver into the position as seen on the picture. Hold the front console cover by hand. Carefully turn the screwdriver counter-clockwise [ccw] (left side) and clockwise [cw] (right side) until the front cover snaps out.



From the rear of the assembly, unscrew the four Phillips screws (left and right position) with a Phillips screwdriver PH2



Remark: For assembling the Front Console Cover/Wind Deflector, please make sure the attachment points are in the correct position and no edge is protruding. Insert the screws slightly and if all screws and the cover are in the correct positions, then tighten them fully.

VECTRIX VX-2 SERVICE MANUAL

SECTION B-3: SPEEDOMETER COVER

Preparations:

Disassemble Front Console Cover/Wind Deflector

see Section B-2

Unplug the connector from the base of the Speedometer



Unscrew the left and right Phillips PH2 screws



Remove the Speedometer and Cover



VECTRIX VX-2 SERVICE MANUAL

SECTION B-4: FRONT VERTICAL PANEL COVER-LOWER

Unscrew the four PH2 Phillips screws (Top + Bottom and Left + Right position)



Slide a Phillips screwdriver into the hole and carefully pull back the cover slowly to the left. Use your fingers to hold the cover and pull backward



Slowly pull back the cover and remove



Remark: To assemble the Front Vertical Panel Cover-Lower, please make sure the attachment points are in the correct position and no edge is protruding. Insert the screws slightly and if all screws and the fairing are in the correct positions, then tighten them fully.

VECTRIX VX-2 SERVICE MANUAL

SECTION B-5: FRONT VERTICAL PANEL COVER-UPPER

Preparations:

Disassemble Front Fairing

see Section B-1

Disassemble Front Vertical Panel Cover-Lower

see Section B-4

Carefully remove Key Switch bezel using a Flathead screwdriver



Key Switch Bezel (removed)



Side view of the inner backside cover



VECTRIX VX-2 SERVICE MANUAL



Unscrew the six remaining PH2 Phillips screws to remove the upper Front Panel cover



VECTRIX VX-2 SERVICE MANUAL

SECTION B-6: CENTER STEP-THROUGH COVER

Preparations:

Disassemble Seat

see Section B-8

Unscrew the two PH2 Phillips screws (left and right position)



Slightly press out left and right side of the cover so that they can clear the frame



Carefully move the cover forward until the cover can easily be removed



Side view of the inner backside cover

Remark: For assembling the Center Step-Through Cover, please make sure the attachment points are in the correct position and no edge is protruding. Insert the screws slightly and if all screws and the fairing are in the correct positions, tighten them fully.



VECTRIX VX-2 SERVICE MANUAL

SECTION B-7: FRONT FENDER

Unscrew the four PH2 Phillips screws (left and right side)



To unscrew the Phillips screws hold the inner nut with 8mm open wrench.



VECTRIX VX-2 SERVICE MANUAL

SECTION B-8: SEAT

Use side Key Latch to raise the Seat

Unscrew the two 8mm hex head screws

Hold the seat during unscrewing the second screw

Remove the seat



Make sure the Seat Latch is in the Open position before checking that the seat lock is properly aligned and works smoothly

VECTRIX VX-2 SERVICE MANUAL

SECTION B-9: UNDER BOARD/BELLY PAN

Remove the two PH2 Phillips screws (left and right position)



Remove the screw (Front position) with a 8mm wrench



Remove the six PH2 Phillips screws in order as seen in the picture

While loosening Screws 5 and 6, hold the Under Board otherwise it drops down and could break!

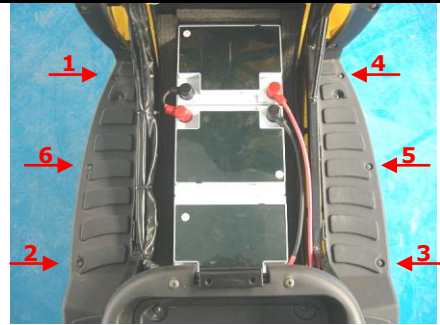

Remark:

When assembling the Under Board/Belly Pan, please make sure the attachment points are in the correct position and no edge is protruding. Insert the screws slightly and if all screws and the fairing are in the correct positions, then tighten them fully.

VECTRIX VX-2 SERVICE MANUAL

SECTION B-10: FOOT REST

Preparations:

Disassemble Center Step-Through Cover

see Section B-6

Disassemble Under Board

see Section B-9

Open the two screws 1 + 2 and the two screws for the side shields with PH2 screwdriver

Same procedure for the other side if necessary



Foot Rest parts + screws



VECTRIX VX-2 SERVICE MANUAL

SECTION B-11: CROSSOVER/REAR TAIL LIGHT ASSEMBLY

Remove four PH2 screws (2 upper and 2 lower)



Carefully slide Crossover/Tail Light Assembly back and upward to avoid breaking the side tab connector in the left and right Body Panels



Unplug Tail Light connector



VECTRIX VX-2 SERVICE MANUAL

SECTION B-12: REAR SIDE BODY PANELS/SIDE EMBLEM

Remove the two lower PH2 Phillips screws first, then the two top screws and remove panel

Repeat procedure for the other panel



Carefully pull out left and right side until the cover can easily lift up

Note: Each Side Emblem is secured with two PH2 Phillips screws

Remark: Note seat lock location on left side panel



Put in the screws slightly and if all screws and the cover are in the correct positions tighten them.

VECTRIX VX-2 SERVICE MANUAL

SECTION B-13: REAR FENDER-TOP

Preparations:

Disassemble Crossover/Rear Tail Light Assembly

see Section B-10

Disassemble Side Body Panels + Side Emblems

see Section B-11

On the right side of the bike, unplug connectors to the Left and Right Turn Indicators and License Plate Light assembly

Unscrew the 3 fasteners with a 8mm open wrench

To remove the Rear Fender Splash Guard, unscrew the two PH2 side screws



VECTRIX VX-2 SERVICE MANUAL

SECTION B-14: SIDE COVER/SWING ARM COVER

Unscrew the four PH2 screws using a Phillips screwdriver

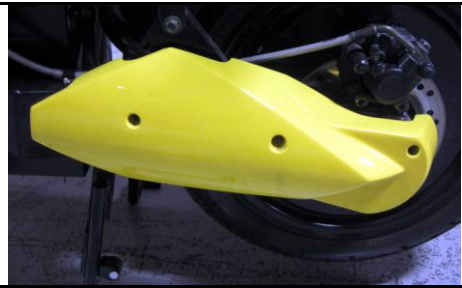

Unscrew the three PH2 screws using a Phillips screwdriver 2 (1 screw is covered by the main stand)



VECTRIX VX-2 SERVICE MANUAL

SECTION B-15: FRONT WHEEL

Preparations:

Disassemble Front Fender

see Section B-7

Remove both plastic covers from the fasteners



Open the two Hex fasteners (#1 + #2) with open wrench 12mm and remove the brake



Put the scooter on a motorcycle lift and elevate the scooter until the front wheel moves freely

Unscrew the nut on the left side by using open wrench 17mm and hold the fastener with open wrench 14mm on the right side (Driver Orientation)



Remove screw (axle) and the other parts and the wheel



VECTRIX VX-2 SERVICE MANUAL

SECTION B-16: FRONT BRAKE MASTER CYLINDER/LINE/CALIPER

Preparations:

Disassemble Front Fairing	see Section B-1
Disassemble Front Console Cover	see Section B-2
Disassemble Speedometer Cover	see Section B-3
Disassemble Front Fender	see Section B-7

Remove hex fastener of the hose clamp with 8mm open wrench

Disassemble the front brake

Now it is possible to exchange the brake pads



Cut all cable ties and unplug the wiring harness of the front brake lever switch



Unscrew both hex fasteners with an Allen key 5mm



VECTRIX VX-2 SERVICE MANUAL

Parts of complete front brake



Remark: For assembling the Front Brake Master Cylinder/Line/Caliper, please make sure the attachment points are in the correct position and no edge is protruding. Insert the screws slightly and if all screws and the fairing are in the correct positions, then tighten them fully.

VECTRIX VX-2 SERVICE MANUAL

SECTION B-17: REAR BRAKE MASTER CYLINDER/LINE/CALIPER

Preparations:

Disassemble Left Foot Rest

see Section B-14

Disassemble Rear Suspension

see Section B-18

Note: To replace the Rear Brake Rotor

see Motor Replacement Procedure C-16

Unscrew the two inner hex bolts by using an Allen key 6mm

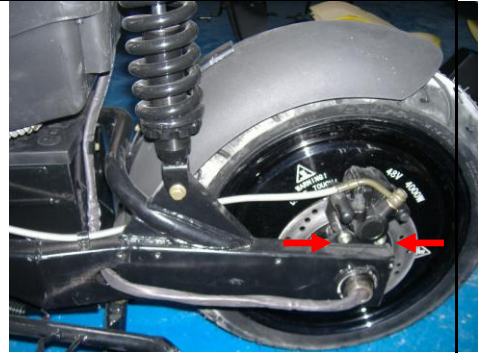

Disassemble the rear brake

Now it is possible to exchange the brake pads

Remark:

It is not necessary to disassemble the side cover of the rear fork as seen in the picture



Remove the two connectors from the brake switch

Remove all cable ties for cable and brake hose

Note: Make sure to route the replacement brake hose along the same path as the original brake hose

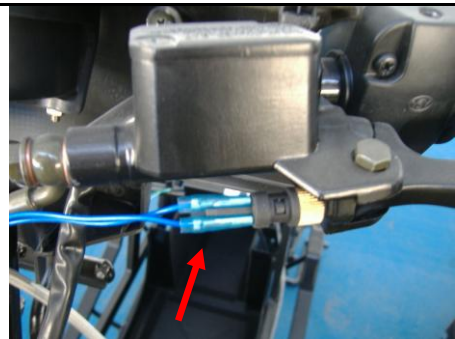

VECTRIX VX-2 SERVICE MANUAL

Remove the two inner hex cap screws from the brake lever assembly by using an Allen key 5mm

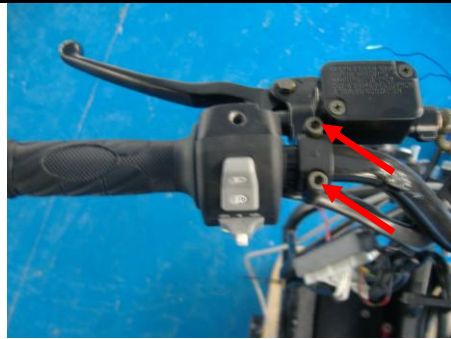

Move the brake hose including the complete brake lever assembly through the frame

Attention:

Do not open the brake system inside the scooter. The brake fluid could damage the paint or other parts.

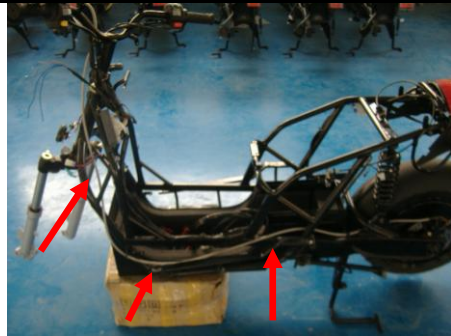

Move the brake hose including the complete brake lever assembly through the frame and rear suspension



Complete removed rear brake assembly



VECTRIX VX-2 SERVICE MANUAL

SECTION B-18: REAR SHOCK

Preparations:

Disassemble Left Side Body Panel

see Section B-12

Unscrew the nut #1 by using a open wrench 14mm
Unscrew the bolt #2 by using a open wrench 13mm
Unscrew the bolt #3 by using a open wrench 12mm and
remove rear shock

Remark:

For disassembling of the rear shock it is not necessary
to remove the motor and the side cover

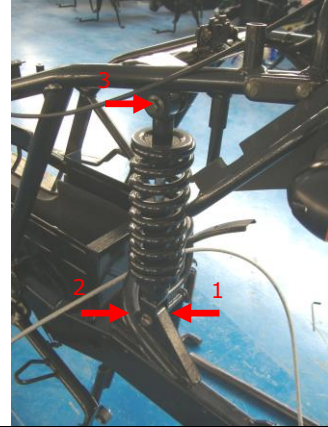

All parts of removed rear shock



Tighten the bolts and the nut according to the required torque, see Section F-4

VECTRIX VX-2 SERVICE MANUAL

SECTION B-19: REAR SWING ARM/MOTOR ASSEMBLY

Preparations:

Disassemble Side Cover/Swing Arm Cover

see Section B-14

Disassemble Motor

see Section C-15

Unscrew 3 inner hex cap bolts and nuts by using an Allen key 4mm and an open wrench 10mm

Remove the rear Mud Guard

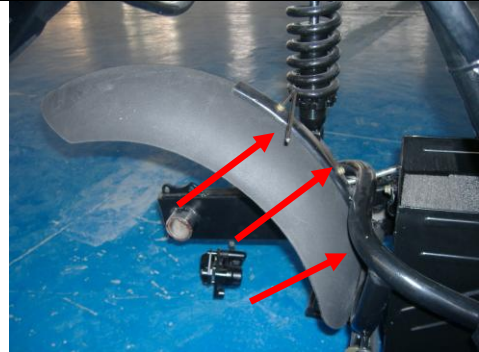

Unscrew the nut #1 by using a open wrench 10mm

Unscrew the bolt #2 by using a open wrench 10mm and remove the bolt

Remark:

It is not necessary to remove any covers or battery

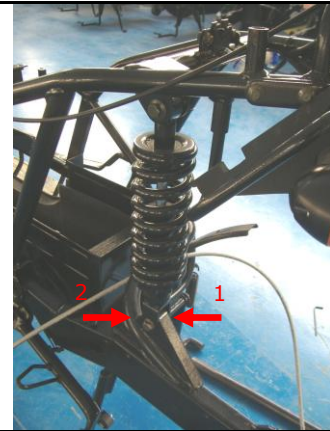

Unscrew the two nuts and hexagon bolts by using 18mm and 19mm open wrench and remove the rear suspension

Remark:

It is not necessary to remove the batteries

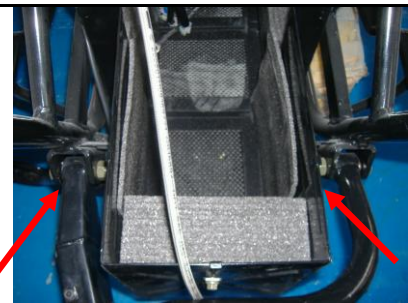

Tighten the bolts and the nut according to the required torque, see Section F-4

VECTRIX VX-2 SERVICE MANUAL

SECTION B-20: HANDLEBAR

Preparations:

Disassemble Front Console Cover

see Section B-2

Disassemble Front Vertical Panel-Lower

see Section B-4

Disassemble Front Vertical Panel-Upper

see Section B-5

Open the connector from the Speedometer

Remove the two cross screws by using a Phillips screwdriver #2 and remove the complete Speedometer cover



Remove all parts of the handlebar

- Left- and right switch assembly
- Left- and right brake handle assembly
- Throttle
- Hand grips + Handlebar weights

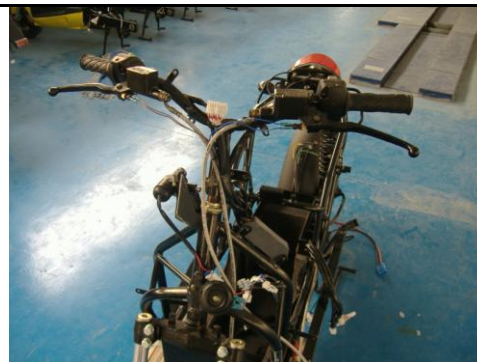

Unscrew the nut #2 by using a open wrench 13mm
Unscrew the bolt #1 by using a open wrench 13mm and remove the bolt

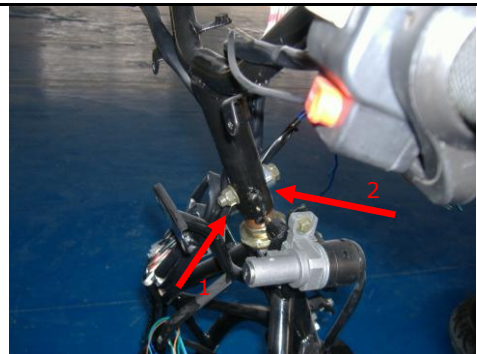

Tighten the bolts and the nut according to the required torque, see Section F-4

VECTRIX VX-2 SERVICE MANUAL

SECTION C

The following **SECTION C** instructions are for the VX-2 **ELECTRICAL** disassembly/assembly. Unless otherwise noted in each procedure, assemble all parts in the reverse order in which they were taken apart. If you have any questions regarding VX-2 Electrical disassembly/assembly procedures, please contact service@vectrix.com.

ICM LOCATION

The Interface Control Module (ICM) is located in one of two locations on the VX-2:



If the VX-2 VIN begins with **LYSE** or **LYSV40002B1000001** through **LYSV40002B1000034**, it is located in the Front Panel-Lower area in the Step-through.



If the VX-2 VIN is **LYSV40002B1000035** or higher, it is located in the Front Console area.



VECTRIX VX-2 SERVICE MANUAL

SECTION C-1: SPEEDOMETER

Preparations:

Disassemble Front Console Cover

see Section B-2

Disassemble Speedometer Cover

see Section B-3

Unscrew both nuts with 8mm open wrench



Remove the plastic bracket

Remark: On the underside of the plastic bracket there are two plastic attachment points which fit into two holes of the plastic cover. These attachment points fixed the Speedometer in the right position.



Carefully remove the Speedometer from the plastic cover



Test functions of speedometer

VECTRIX VX-2 SERVICE MANUAL

SECTION C-2: THROTTLE

Preparations:

Disassemble Front Vertical Panel-Lower	see Section B-4
Disassemble Front Vertical Panel-Upper	see Section B-5
Disassemble Front Console Cover	see Section B-2

Lower Regen Throttle Box Replacement S-XC-S00077

Tools Required:

PH #2
8mm Turned Full-contact Hexagonal Socket (S02445)

Removal Procedure

1. Turn ignition key to the off position.
2. Remove three screws (#3, #3, #4) from the lower throttle box assembly.
3. Lift the kill switch housing (1) up and away from lower box.
4. Using 8mm Hexagonal Socket S02445 remove two lower box U-Bolt nuts (5).

Note the orientation of the throttle return spacers and spring for reassembly.

5. Remove the U-Bolt (6). Pull down on the lower box (2) and remove.
6. Slide the throttle assembly off of the handlebar.

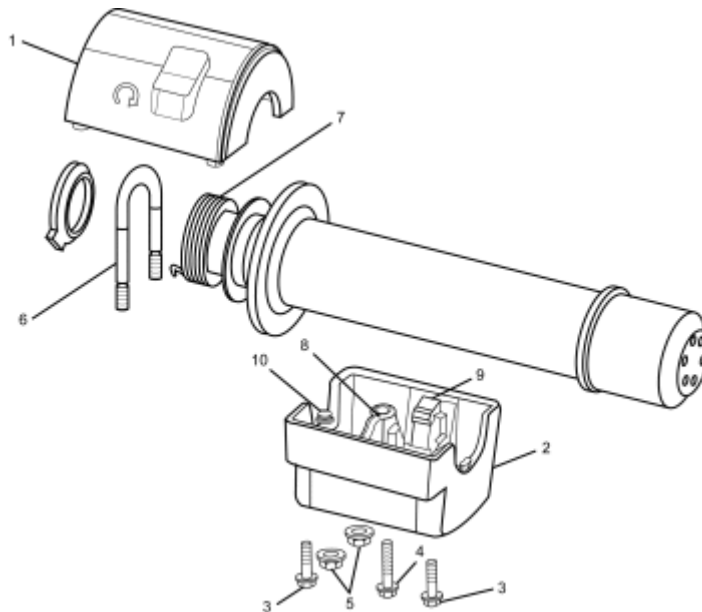

VECTRIX VX-2 SERVICE MANUAL

Installation Procedure

1. Install the U-Bolt (6) into the box and start one of the nuts on the first thread of the rear stud of the U-Bolt.
2. Slide the assembly onto the handlebar; ensure that the kill switch harness is installed into the slot of the lower box.
3. With the lower box pivoted away from the handlebar slide the throttle assembly onto the handlebar.
4. Position the return spring (7) onto the spring post (8) of the lower box and twist the throttle until the throttle stop is resting on the lower box throttle stop (9).
5. Ensure that the tab (10) on the bottom of the lower box is into the hole in the handlebar.
6. Using tool 01545, install the other U-Bolt nut and tighten both nuts.
7. Twist the throttle to ensure free movement and that it returns to a neutral position.
8. Using 8mm Hexagonal Socket S02445, install the kill switch cover onto the box and install the 3 screws, tighten. Alternate tightening of the 2 nuts until reaching a torque value of 2 Nm.
9. Check the Regen Throttle adjustment. Refer to Throttle Position Checking Procedure.

Note: If needed, to remove the old throttle position magnet sensor, install the new sensor magnet and screw it in until lightly seated, then back out 1 full turn. Continue to unscrew the throttle position magnet sensor until the throttle is properly aligned.

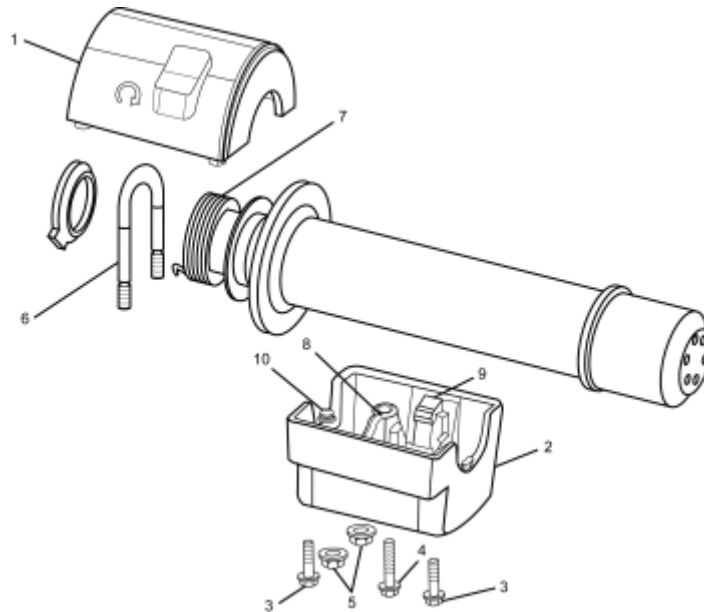

Regen Throttle Adjustment Procedure

Note: Key must be in "ON" position and Kill Switch in the "OFF" position

1. Remove the right handlebar end cap. Refer to Handlebar End Cap and Hand Grip Replacement.
2. Slightly loosen the set screw (1).

VECTRIX VX-2 SERVICE MANUAL

3. To determine the current position of the Throttle, squeeze the left side brake lever and using a large rubber band or similar device secure the lever in the squeezed position, and observe the needle position.

4. To determine the correct position of the Throttle, squeeze the right side brake lever and observe the reading.

Note: The neutral position of the throttle is 615-639. The ideal setting for this adjustment is 625.

5. Release the right lever and adjust the screw (2) until the readings are the same.

6. Remove the large rubber band or similar to release the left side brake lever.

7. Slightly tighten the set screw; this will secure the screw from moving.

8. Install the right handlebar end cap.

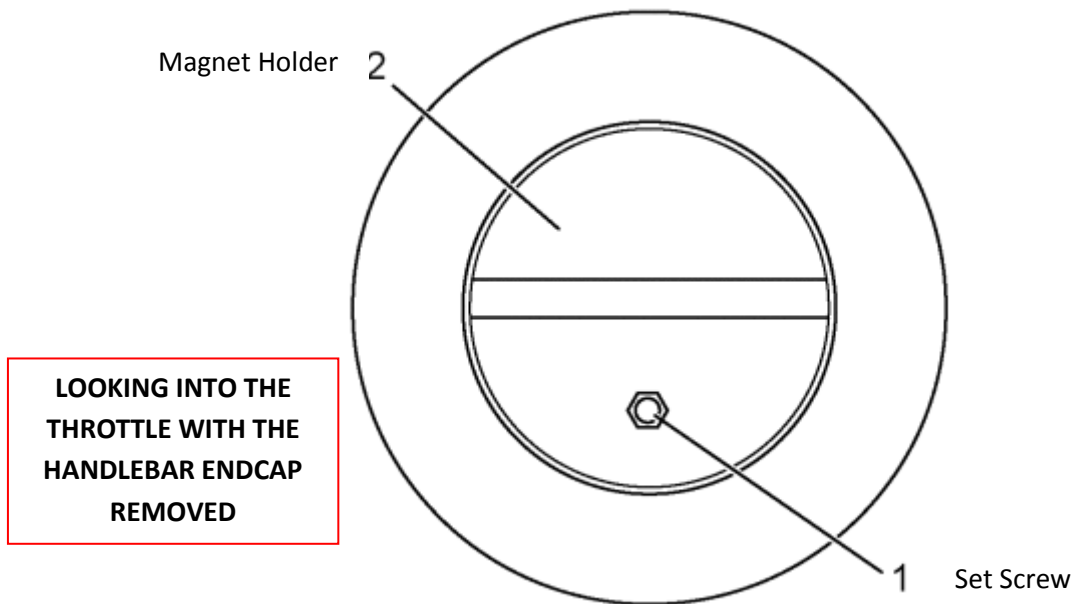

Regen Throttle Sensor Replacement

S-XC-S00079

Removal Procedure

1. Remove the upper handlebar cover. Refer to Front Console Cover Replacement B-2.
2. Remove the right handlebar end cap and hand grip. Refer to Handlebar End Cap and Hand Grip Replacement.
3. Remove the kill switch cover screws.
4. Twist the throttle to gain access to the throttle clamp screw (1) and loosen.
5. Remove the throttle sleeve (2) from the handlebar.

VECTRIX VX-2 SERVICE MANUAL

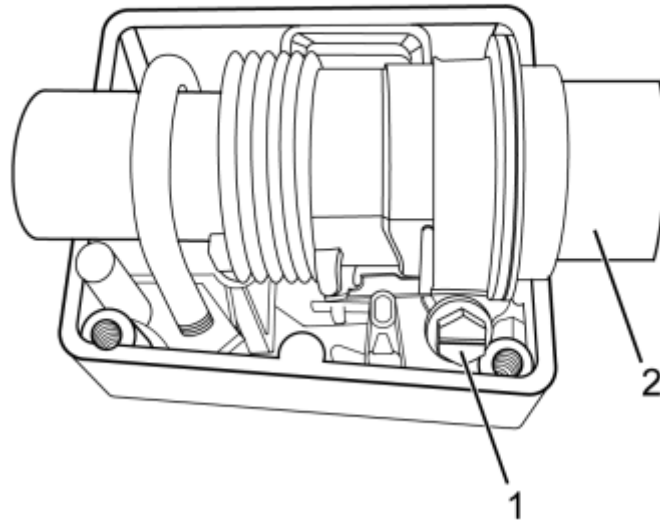

6. Loosen the Throttle set screw (1) and remove the sensor magnet (2).

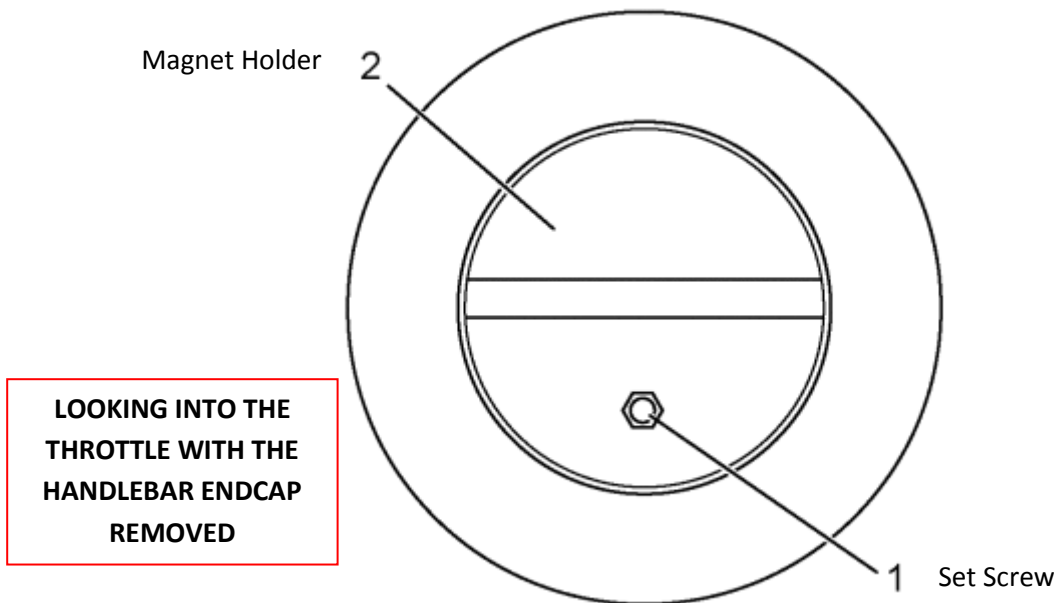

VECTRIX VX-2 SERVICE MANUAL

7. Remove the screws (1) and slide the insert and sensor out of the handlebar.

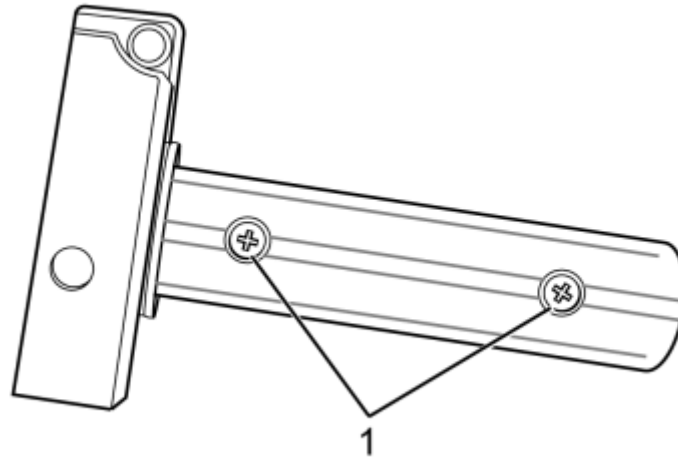

8. Remove the sensor (1) from the insert.

9. Mark and remove the sensor wires from the handlebar connector and remove the sensor.

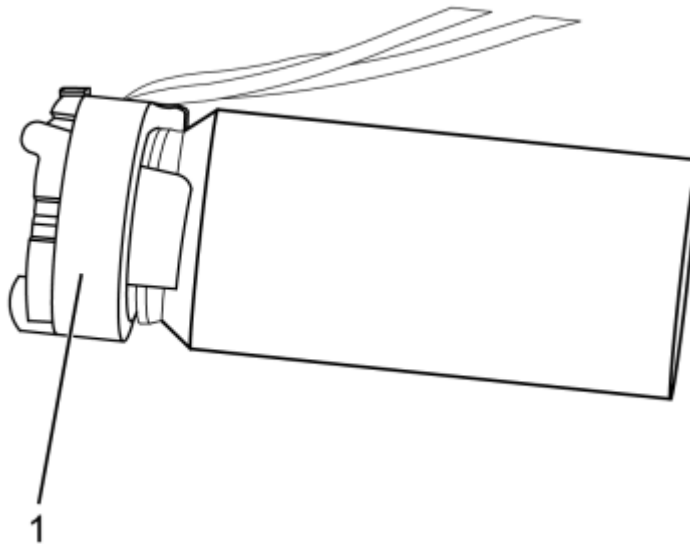

VECTRIX VX-2 SERVICE MANUAL

Installation Procedure

1. Install the sensor wires through the handlebar and out the harness hole.
2. Install the sensor wires into the connector in the same location as removed.
3. Install the sensor (1) onto the insert.

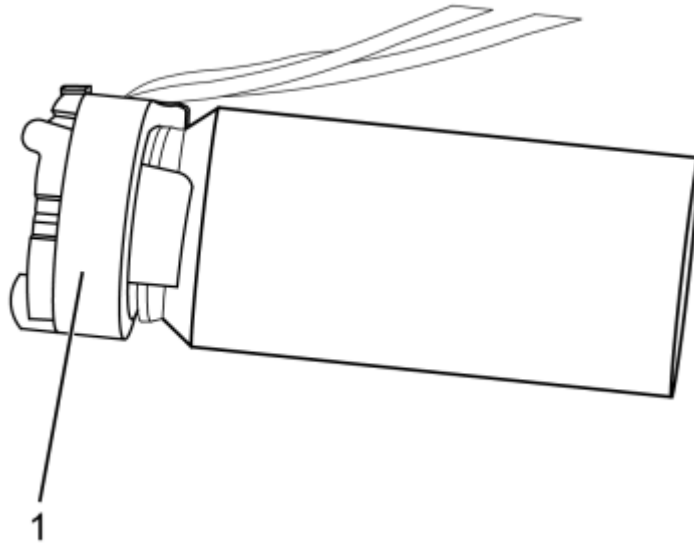

4. Install the insert and tighten the screws (1).

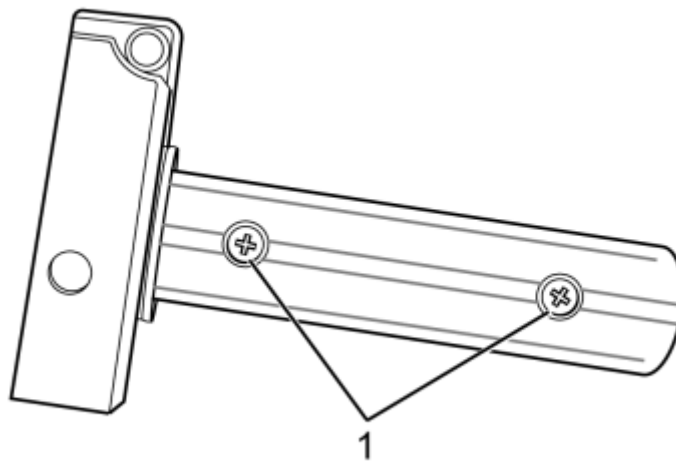

VECTRIX VX-2 SERVICE MANUAL

5. Install the throttle sleeve (2) onto the handlebar and into the plastic sleeve.

Notice: Refer to Fastener Notice in General Information.

6. Twist the throttle sleeve into the full Regen position (forward) and tighten the throttle clamp screw (1).

Tighten

Throttle clamp screw 2.5 Nm (22 lb in)

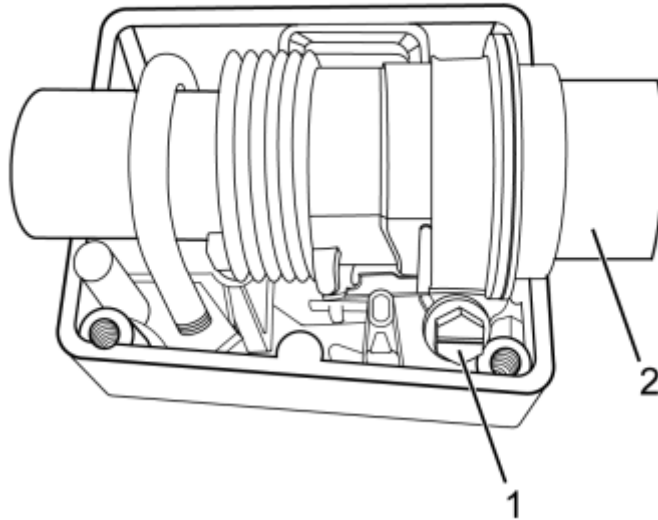

7. Install the kill switch cover, and screws and tighten.

8. Verify smooth operation of the throttle by rotating back and forth and assuring spring return to the neutral position.

9. Install the upper handlebar cover. Refer to Front Console Cover Replacement.

10. Install the sensor magnet and screw in until lightly seated then back out 1 full turn.

11. Check the adjustment of the Regen Throttle. Refer to Throttle Position Checking Procedure.

12. Install the right handlebar end cap and hand grip. Refer to Handlebar End Cap and Hand Grip Replacement.

Regen Throttle Position Checking Procedure

S-RW-100000

Without PC

Note: This procedure is to be used when a PC is not available. This adjustment **MUST** be verified using the PC method.

1. Place the ignition key in the ON position and the kill switch in the ON (non-run) position.

2. Squeeze the left side brake lever and observe the speedometer needle (1). This reading is the actual setting of the Regen Throttle.

3. Continue to squeeze the left side and then squeeze the right side brake lever and observe the

VECTRIX VX-2 SERVICE MANUAL

speedometer needle. This is the required setting and what the actual reading in Step 3 must be set to. If the settings are not the same refer to Throttle Adjustment Procedure.



With PC

1. Connect the Diagnostic Hardware. Refer to Diagnostic Hardware Connections.
2. Open the Vectrix diagnostic program, by clicking on the ScooterDiag icon. This will open up the Scooter Diagnostics Summary page.
3. Within the General Information box, click on the “Show Instrument” button. This will open up an instrument cluster page.
4. In the lower center of the page is the throttle setting. This setting color should be in the Green, if the color is Red, the throttle is out of adjustment and must be adjusted. Refer to Throttle Adjustment Procedure.

VECTRIX VX-2 SERVICE MANUAL

SECTION C-3: BRAKE SWITCH

(Both Left and Right)

Preparations:

Remove Front Console Cover (for VIN all LYSE and LYSV40002B1000001 to LYSV40002B1000034) see Section B-2

Remove Vertical Panel Cover-Lower (for ICM access for VIN all LYSE and LYSV40002B1000001 to LYSV40002B1000034) see Section B-4

Remove all cable ties (1)

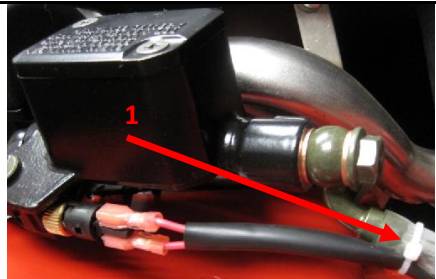

Remove connector from the Interface Control Module (ICM)



Disconnect both wires at the brake switch connector and twist out (by hand) the brake switch at the brass coupling

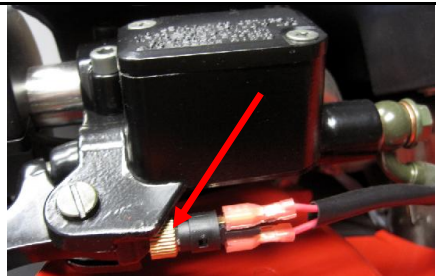

Test functions of Brake Switch assembly

VECTRIX VX-2 SERVICE MANUAL

SECTION C-4: HANDLEBAR-LEFT SWITCH ASSEMBLY

Preparations:

Remove Front Console Cover (for VIN all LYSE and LYSV40002B1000001 to LYSV40002B1000034) see Section B-2

Remove Vertical Panel Cover-Lower (for ICM access for VIN all LYSE and LYSV40002B1000001 to LYSV40002B1000034) see Section B-4

Remove all cable strips

Open connector CN1 from the Interface Control Module (ICM)

Additional information see Section 1 of F-1



Unscrew the PH2 Phillips screw



Unscrew the PH2 Phillips screw

Remove the Left Switch assembly

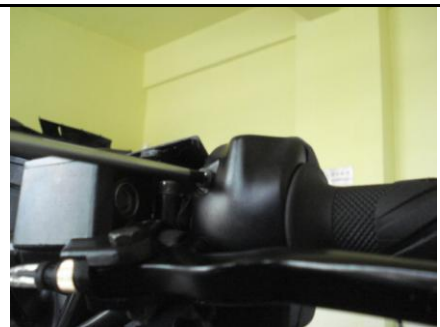

Test functions of Left Switch assembly

VECTRIX VX-2 SERVICE MANUAL

SECTION C-5: HANDLEBAR-RIGHT SWITCH ASSEMBLY

Preparations:

Remove Front Console Cover (for VIN all LYSE and LYSV40002B1000001 to LYSV40002B1000034) see Section B-2

Remove Vertical Panel Cover-Lower (for ICM access for VIN all LYSE and LYSV40002B1000001 to LYSV40002B1000034) see Section B-4

Remove all cable strips

Open connector CN3 from the Interface Control Module (ICM)

Additional information see Section 1 of F-1



Unscrew the PH2 Phillips screw

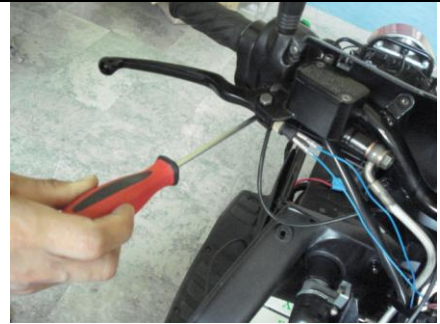

Unscrew the PH2 Phillips screw

Remove the Right Switch assembly



Test functions of Right Switch assembly

VECTRIX VX-2 SERVICE MANUAL

SECTION C-6: IGNITION SWITCH

Preparations:

Disassemble Front Fairing	see Section B-1
Disassemble Front Console Cover	see Section B-2
Disassemble Vertical Panel Cover-Lower	see Section B-4
Disassemble Vertical Panel Cover-Upper	see Section B-5

Remove all cable ties

Open connector

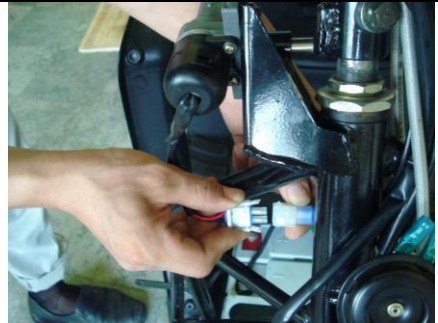

Unscrew the two fasten bolts of Key switch by 10mm socket wrench



Test function of the Key switch

Remark: Since the ignition key and the lock for the seat are the same, it is recommended that they be changed as a matched set. Otherwise, two different keys are necessary.

VECTRIX VX-2 SERVICE MANUAL

SECTION C-7: HORN

Preparations:

Disassemble Front Fairing	see Section B-1
Disassemble Front Console Cover	see Section B-2
Disassemble Vertical Panel Cover-Lower	see Section B-4
Disassemble Vertical Panel Cover-Upper	see Section B-5

Open the connector of the horn



Unscrew the bolt by 10mm open end wrench



Test function of Horn

VECTRIX VX-2 SERVICE MANUAL

SECTION C-8: POSITION LIGHT/HEADLAMP ASSEMBLY

Preparations:

Disassemble Front Fairing

see Section B-1

Headlamp Assembly Replacement

Headlamp Assembly Part #S-XC-S00092

Removal Procedure

1. Remove the right front fairing. Refer to Front Fairing Replacement in Body Front End.
2. Remove the headlamp bolts (1).

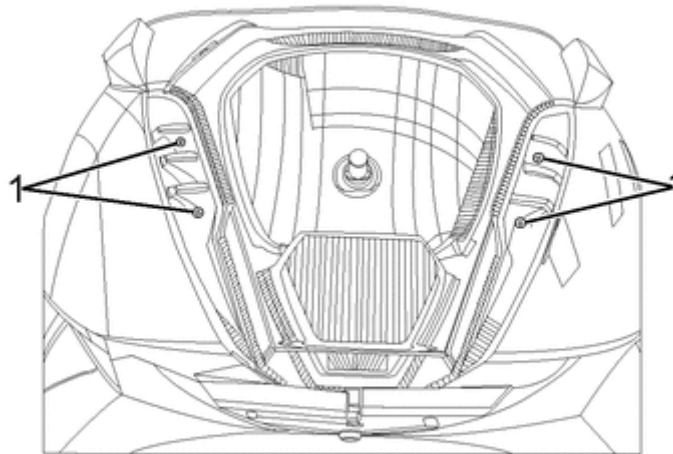

VECTRIX VX-2 SERVICE MANUAL

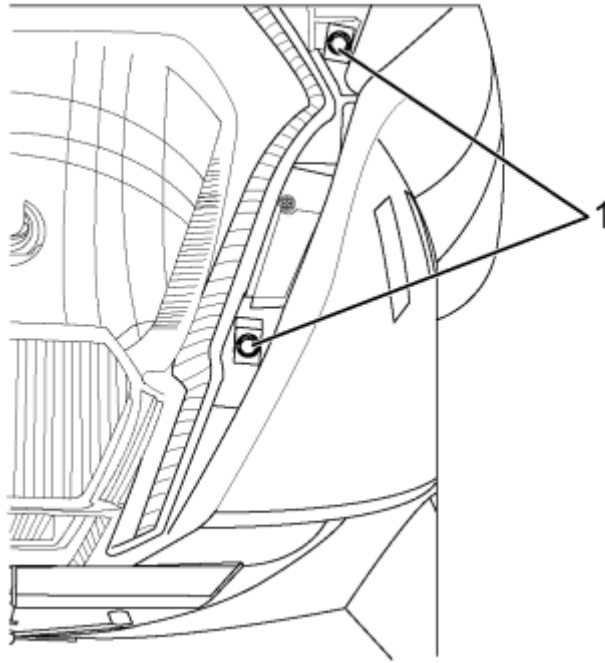

3. Pull the headlamp off the front sub-frame enough to remove the lamp harness connectors.
4. Remove the lower marker lamp bulb connector.
5. Disconnect Headlamp Assembly connectors and replace with new Headlamp Assembly.
6. Connect the headlamp and lower marker lamp connectors.
7. Install the headlamp assembly onto the left front fairing and install bolts (1). Tighten Headlamp bolts to 2 Nm (18 lb in)

Note: Refer to Fastener Notice in General Information.

VECTRIX VX-2 SERVICE MANUAL

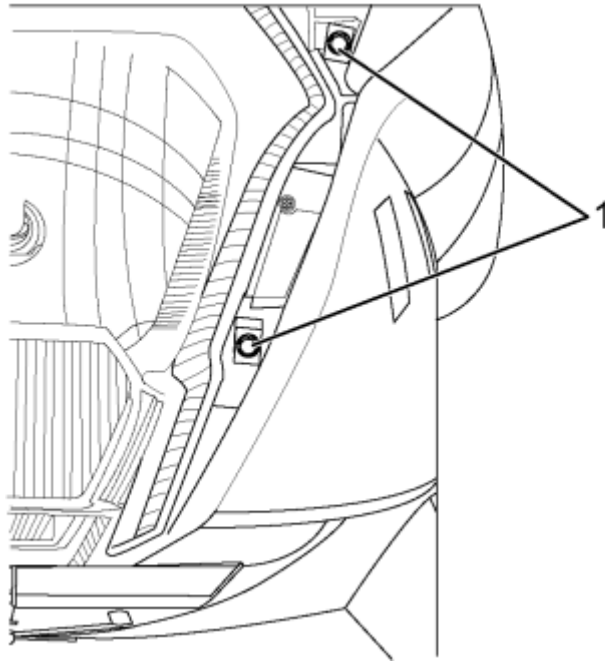

9. If the headlamp assembly was replaced aim the headlamp. Refer to Headlamp Adjustment Procedure.

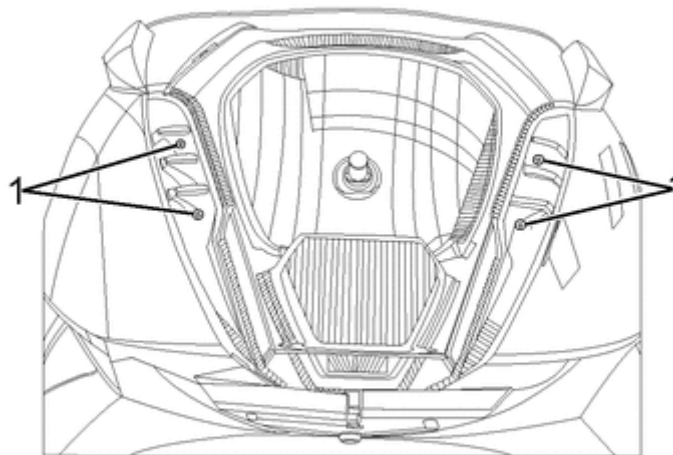

VECTRIX VX-2 SERVICE MANUAL

SECTION C-9: FRONT TURN INDICATOR ASSEMBLY **(Both Left and Right)**

Preparations:

Disassemble Front Fairing

see Section B-1

Remove all cable strips

Remove connector (2-pins) of the Turn Indicator Light

Remark: Procedure is the same for both Turn Indicator Lights (Right and Left)

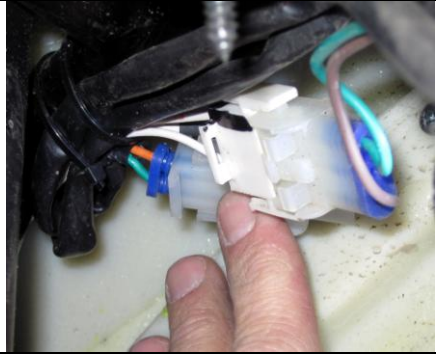

Unscrew the Nut from the inside with a wrench



Remove entire Front Turn Signal Assembly and pull cord through the hole.

Replace entire Front Turn Signal Assembly

Remark: Since the assembly is LED, you must replace the whole assembly.



Test function of Front Turn Indicator Light Assembly

VECTRIX VX-2 SERVICE MANUAL

SECTION C-10: SIDE STAND SWITCH

Preparations:

Disassemble Center Step-Through Cover see Section B-6

Remove the connector inside of the electronic box
under the seat



Unscrew the bolt by 8mm open end wrench



Test function of Side Stand Switch

VECTRIX VX-2 SERVICE MANUAL

SECTION C-11: REAR TAIL LIGHT ASSEMBLY

Preparations:

Disassemble Crossover Tail Light Assembly

see Section B-11

Remove all cable strips

Open 3-pin connector

Unscrew the two side screws and one middle screw with Phillips screwdriver

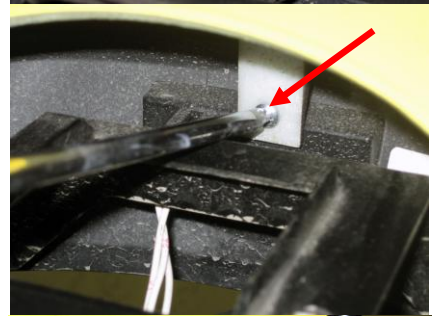

Replace entire Tail Light Assembly

Note: The Rear Tail Light is LED, you must replace the whole assembly.



Test function of Brake **and** Position lights

VECTRIX VX-2 SERVICE MANUAL

SECTION C-12: LICENSE PLATE LIGHT ASSEMBLY

Unscrew the two PH2 Phillips screws

Remove plastic cover



Pull out the defect bulb

Remark: Don't touch the glass body of the new bulb with your fingers, use a tissue



Test function of License Plate Light

VECTRIX VX-2 SERVICE MANUAL

SECTION C-13: REAR TURN INDICATOR LIGHT ASSEMBLY

Remove all cable ties

Open 2-pin connector



Cut the cable of the Rear Indicator Light assembly

Remark: Connector has to be cut because the connector doesn't fit through the hole of the plastic



Remove the nut with an open wrench 14mm

Pull out the Rear Turn Indicator assembly



Replace entire Rear Turn Indicator Assembly

Note: The Rear Turn Indicator Assembly is LED so you must replace the entire assembly.

Remark: Slightly push in the pins into the new connector. Be sure of the right position. Refer to the old connector



Test functions of Rear Turn Indicators

VECTRIX VX-2 SERVICE MANUAL

SECTION C-14: MOTOR CONTROLLER

Open the seat and remove Cover of electronic box



Turn Key Switch to "ON" Position



Unplug blue Battery Main Connector



Turn Key Switch to "OFF" Position

Disconnect Positive Terminals first and remove Main Fuse (1)

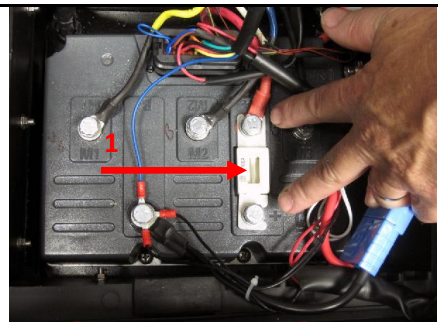

Then disconnect remaining (Negative) cables and wiring harness

Unscrew the four Phillips bolts at the base of the Motor Controller to remove the Motor Controller

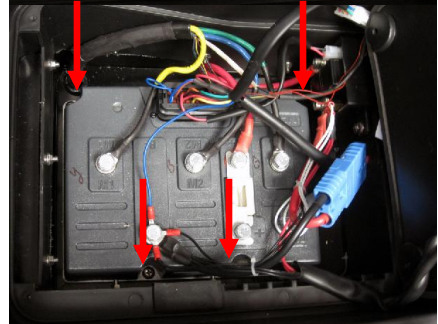

VECTRIX VX-2 SERVICE MANUAL

Install new Motor Controller and re-secure with four Phillips bolts

Reconnect Negative Cables and Wiring Harness first

Then replace Main Fuse and Positive Cables next

Reconnect the blue Battery Connection Cable



VECTRIX VX-2 SERVICE MANUAL

SECTION C-15: MOTOR

Preparations:

Disassemble Side Cover

see Section B-15

Disassemble Rear Brake

see Section B-16

Note: This is the same procedure to replace the Rear Brake Rotor

Open the seat and remove Cover of electronic box



Turn Key Switch to "ON" Position



Unplug blue Battery Main Connector



Turn Key Switch to "OFF" Position

For safety reasons, disconnect Positive Terminals first and remove Main Fuse (1)

Disconnect remaining (Negative) Cables and Wiring Harness

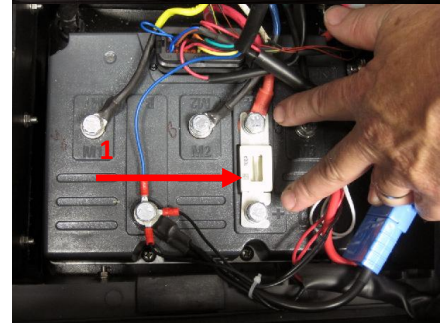

VECTRIX VX-2 SERVICE MANUAL

Unscrew the nut by using a 8mm open wrench and remove the cable clamp

Pull out the motor cables from the electronic box



Unscrew the motor nut with the Vectrix EM-90400 Special spanner socket



Remove the motor/rear wheel assembly in the direction of the arrow on the picture.



All parts of removed motor



Test function of Motor

VECTRIX VX-2 SERVICE MANUAL

SECTION C-16: BATTERY

Preparations:

Disassemble Front Vertical Panel Cover-Lower
Disassemble Center Step-Through Cover

see Section B-4
see Section B-6

Note: Photos in this section show the electronic box removed which makes the procedure easier to complete but is not necessary if only the Step-Through panel is removed.

VX-2 BATTERY LAYOUT



Disconnect Blue Battery Power Cable



Disconnect Blue Battery Power Cable



Unscrew the hexagon bolts from Battery #1 and #3

VECTRIX VX-2 SERVICE MANUAL

Note: After disconnecting Battery #3, use electrical tape to insulate the loose terminal end from Battery #4



Lift up the Middle Battery (#2) as shown and remove it. Each battery typically weighs **XXXX** pounds/**XXXX** kg.

Remark:

Batteries are fixed to the battery case with strong Velcro. Move the batteries sideways to loosen them from the Velcro before removal.



Lift up Front Battery (#1) as shown and remove it



Lift up Middle Rear Battery (#3) as shown and remove it

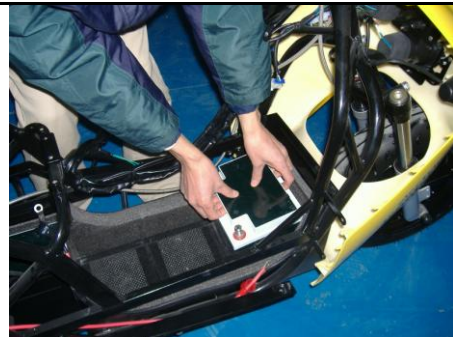

VECTRIX VX-2 SERVICE MANUAL

Slide forward then lift up Rear Battery (#4) and remove it



Empty battery case for 60AH



After replacing the Batteries:

- Measure the voltage of each battery. It should be higher than 12.0 VDC.
- Charge the battery **before** use!

VECTRIX VX-2 SERVICE MANUAL

SECTION C-17: BATTERY CHARGER

Put Key into key hole on the side of the VX-2 to open Under Seat Storage Area.



Turn Key to open Under Seat Storage Area

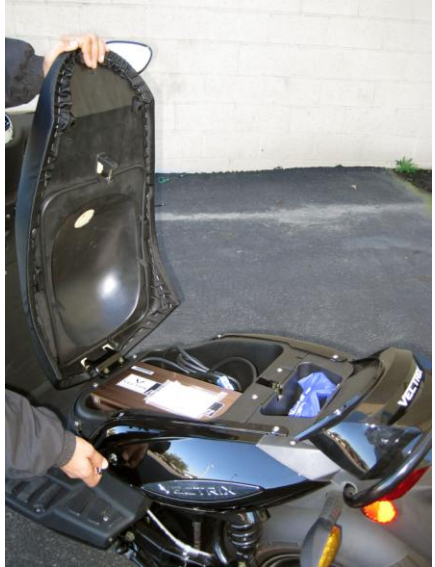

Remove Battery Charger from Under Seat Storage Area



VECTRIX VX-2 SERVICE MANUAL

Plug blue Battery Charger male connector cord into on-board blue Battery Charger female connection.

Plug Battery Charger AC connector into a AC main.



Turn on Battery Charger Unit power switch.



Recharge until Battery Charger Output LED reaches 100% (Green).

Note: Recharge process can be discontinued and re-started at any time during the charge cycle



VECTRIX VX-2 SERVICE MANUAL

SECTION D-1: FRONT HEADLAMP/POSITION LIGHT ADJUSTMENT

Headlamp Aiming

S-ST-100000

Properly aim the headlamp for maximum road illumination and safety. With halogen headlamps, proper aiming is very important. The increased range and power of these lamps make even the slightest variations from the recommended aiming hazardous to approaching motorists.

Observe the following conditions when you inspect or adjust the headlamp aim:

- The scooter is on a level surface.
- The tires are uniformly inflated to the specified pressure.
- One person is sitting on the driver's seat.
- The scooter is in the vertical position.
- Clean the headlamp before aiming.
- Follow your state's requirements for headlamp aiming.

Headlamp Aiming Location

- The aiming area should be darkened and large enough to allow for the scooter and an additional 10 m (33 ft), measured from the face of the headlamp to the front of the screen.
- The floor on which the vehicle rests must be parallel with the bottom of the screen. If the floor is not level, compensate accordingly.

Headlamp Aiming Procedure

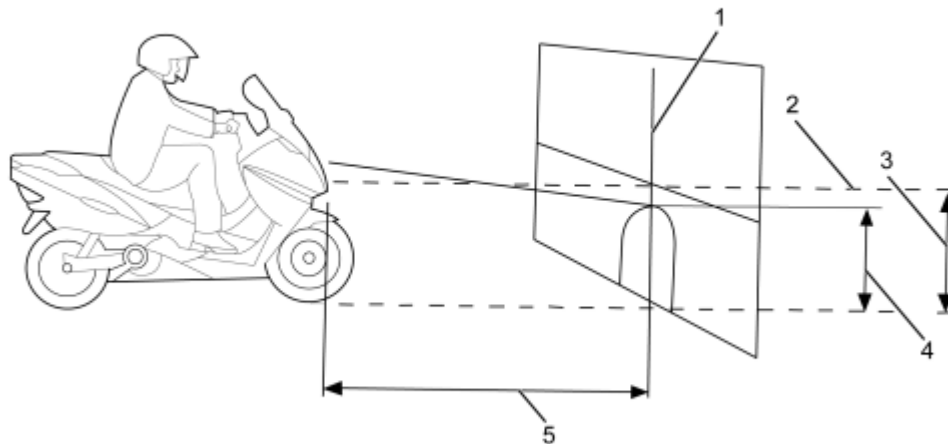

1. Position the scooter square with the screen, with the headlamp directly over the 10 m (33 ft) reference line (5).
2. Ensure that the vehicle is on a level surface.
3. Draw a horizontal reference line (2) that is in the center of the headlamp.

VECTRIX VX-2 SERVICE MANUAL

4. Draw a vertical reference line (1) that is in line with the scooter axis.
5. With the headlamp low beam on the height spot (4) should 9/10th of the headlamp center line (3).

Adjusting the headlamp

1. To adjust the light beam up and down turn the right lower side adjustment screw. Clockwise to raise the beam and counterclockwise to lower the beam.
2. To adjust the light beam side-to-side turn the upper left adjustment screw. Clockwise to move the beam to the right and counterclockwise to move the beam to the left.

VECTRIX VX-2 SERVICE MANUAL

SECTION E-1: INDICATION ON SPEEDOMETER DISPLAY & CONTROLLER LED

Indication on LCD	Controller LED Flash Count	Reason	Solution
Accelerator turn at power up	1	Accelerator is not in zero position	Release accelerator or turn power "OFF" and then to "ON" or proceed to the Accelerator troubleshooting diagram
Error Accelerator Volt	2	Accelerator voltage too high	Release accelerator or turn power "OFF" and then to "ON" or proceed to the Accelerator troubleshooting diagram
Stop scooter Battery empty!	3	Battery voltage is under 42V permanently	Charge the Battery
Error Overcurrent	4	Controller defect	Exchange controller and check motor for short winding against housing
Error Hall sensor	5	Hall sensor Malfunction of the motor	Proceed to Hall Sensor check Section 4 of Section E
Scooter Disabled	6	This messages comes after Stop scooter	Solve malfunction before this message
Error Voltage too high	7	Battery voltage is over 63V	Use the scooter carefully until message is over, if not, check if the real voltage of the battery is lower than 63V and setting of controller. Or exchange Controller.
Error High temperature	9	Temperature of the controller is >85 °C	Wait until temperature goes down under 85 °C. Or exchange Controller
Stop scooter High temperature	10	Temperature of the controller is >110 °C	Wait until temperature goes down under 110 °C. Or exchange Controller
Low Battery Recharge!	11	Battery voltage is under 42V > 15 seconds	Charge the Battery
Error Side Stand out	12	Side stand switch is active	Check correct function of side stand switch. Exchange Side Stand Switch or controller
System Error 01		Memory of speedometer defect	Exchange Speedometer if message is still there.

The LED on the controller flashes if a malfunction is active.

Example: LED flash 6 times with 1 Hz, LED off for 2 sec. and starts again.
This means: Disable function active

VECTRIX VX-2 SERVICE MANUAL

SECTION E-2: MALFUNCTIONS

- **No Top Speed**
 - Check setting of the controller
 - Check correct function of the throttle, adjust or exchange if needed

- **No function and no indication** on Speedometer
 - Check Fuse 1 (15A) of the converter
 - Check voltage on Controller power in line (red and black thick wire) should be higher than 36 V.

 - Converter broken

- Full function but **no indication** on Speedometer
 - Check connection of the speedometer
 - Speedometer broken

- No indication of the **energy bar** on Speedometer
 - Check Voltage of the battery
 - Check Voltage on Pin 1 of the speedometer connector. Should be the battery Voltage

 - Speedometer or controller broken or wire between controller and speedometer

- No indication of the **consumption bar** on Speedometer
 - Check Voltage of the battery
 - Check Voltage on pin 1 of the Speedometer connector. Should be the battery Voltage

 - Speedometer or Controller broken or wire between Controller and Speedometer

- No **change of battery voltage and mph/kph** on Speedometer
 - Check correct function of MODE switch
 - Mode switch or Speedometer broken

- No indication of **speed** on Speedometer but motor running is okay
 - Check if the Voltage on Pin 5 of the speedometer connector. Should change if Motor is turned by hand.

 - Speedometer or Controller broken or wire between Controller and Speedometer

VECTRIX VX-2 SERVICE MANUAL

SECTION E-3: CHECK OF CHARGER FUNCTION

1. Normal function

If the Charger is connected and the indication led on the charger is at 60%, turn on the scooter and the battery voltage indication of the speedometer should show $59.5\text{ V} \pm 1.0\text{ V}$.

During the charging process at 60%, the current should be $10.0\text{ A} \pm 0.8\text{ A}$, measured with a clamp ampere meter on the brown wire close to the charger DC-plug.

If not, check the voltage with a digital voltmeter on the Controller power in line (red and black thick wire). The value should be $59.5\text{ V} \pm 1.0\text{ V}$. If yes, exchange speedometer, if not, exchange Charger.

2. Charger didn't start

Using a Digital Multi meter:

- Open the cover seat

- Measure on the charger connector of the scooter if the voltage is like the battery voltage indication of the speedometer. If the voltage is zero, check the fuse #2 (30A) of the converter or the connection cable. If the voltage is lower than 33 V check the voltage of each battery and exchange the battery which is lower than 10.0V.

- Exchange Charger

VECTRIX VX-2 SERVICE MANUAL

SECTION F-1: CABLE ASSEMBLY-FRONT BRAKE/INDICATORS + BOM

NOTES:

1. ALL NUMBERS IN BALLOONS REFERENCED ON SHEET 2 BOM.
2. FOLLOW WORKMANSHIP STANDARDS IN ACCORDANCE WITH IPC-620 OR IEC 60332-1
3. CRIMP IN ACCORDANCE WITH CONNECTOR MANUFACTURER'S SPECIFICATIONS.
4. WIRE GAUGE LISTED IN BOM.
5. CONNECTOR VIEWS SHOWN FROM WIRE ENTRY SIDE, WHERE APPLICABLE.
6. 1 REQ'D PER SCOOTER ASSEMBLY

REVISIONS		DWG NO. 002282		
REV.	DESCRIPTION	DATE	BY	NAME
01	RELEASED FOR PRODUCTION	11 JUN 10	PTB	19578

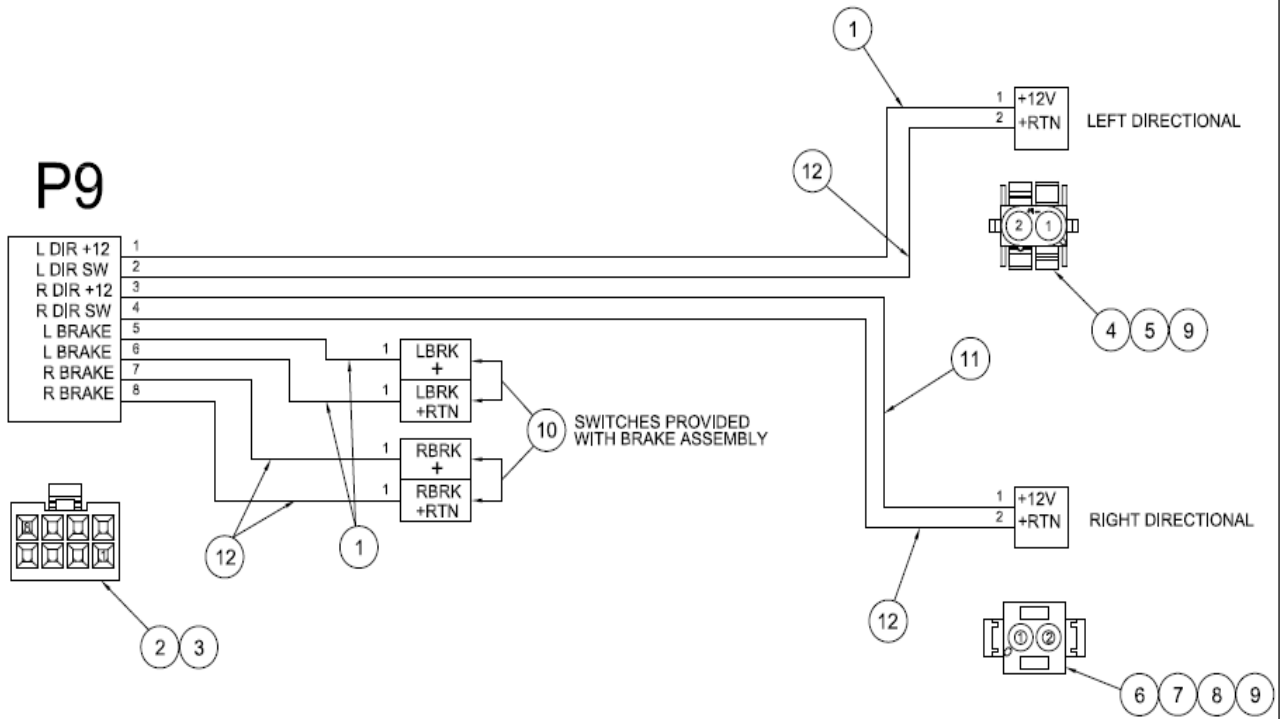

CONFIDENTIAL PROPRIETARY INFORMATION; THIS ITEM IS THE PROPERTY OF VECTRIX CORPORATION, AND CONTAINS INFORMATION. THIS ITEM MAY NOT BE TRANSFERRED FROM THE CUSTODY OR CONTROL OF VECTRIX EXCEPT WITH THE PRIOR WRITTEN CONSENT OF VECTRIX AND THEN ONLY BY THE WAY OF LOAN FOR LIMITED PURPOSES. IT MUST NOT BE REPRODUCED IN WHOLE OR IN PART, AND MUST BE RETURNED TO VECTRIX UPON REQUEST AND IN ALL EVENTS UPON COMPLETION OF THE PURPOSE OF THE LOAN, NEITHER THIS ITEM NOR THE INFORMATION IT CONTAINS MAY BE USED BY OR DISCLOSED TO PERSONS NOT HAVING A NEED FOR SUCH ITEM OR INFORMATION CONSISTENT WITH THE PURPOSE OF THE LOAN, WITHOUT THE PRIOR WRITTEN CONSENT OF THE VECTRIX CORPORATION.

DIMENSIONS IN INCHES UNLESS OTHERWISE SPECIFIED
 DEFAULT TOLERANCES:
 DECIMALS .XXX ± 0.005
 ".XX ± 0.01
 ANGLES °, ' ± .1°
 DO NOT SCALE DRAWING

OWNER	PAUL GAUDETTE	DESIGN		DRAWN	
DATE	07 JUN 10	SIZE		DWG	
STATUS	N/A				
REVISION	N/A				

VECTRIX		55 SAMUEL BARNETT BLVD, NEW BEDFORD, MA 02745 USA	
TITLE: CABLE ASSEMBLY FRONT BRAKE & DIRECTIONALS VECTRIX VX-2 ELECTRIC SCOOTER			
SCALE	NONE	REV.	01
		ISS	C
PART NO.	002282	DWG NO.	002282
		SHEET	1 OF 2

VECTRIX VX-2 SERVICE MANUAL

TITLE			BOM-CABLE ASSEMBLY FRONT BRAKE & DIRECTIONALS VECTRIX VX-2+ ELECTRIC SCOOTER		REV. 01	
LINE NO	REFERENCE DESIGNATION	QTY	PART NO.	PACKAGE	PART DESCRIPTION	MFR
1	1	A/R			WIRE, 18 AWG, TINNED, RED, 300V, PVC INSULATION	ANY SUITABLE MFR.
2	2	1	0039012080		CONNECTOR, 4.20mm (.165") PITCH, MINI-FIT Jr., DUAL ROW, 8 PIN	MOLEX
3	3	8	39-00-0208		CRIMP TERMINAL, FEMALE, AWG 18-24	MOLEX
4	4	1	1-480699-0		CONNECTOR HOUSING, UNIVERSAL MATE-N-LOK, 2 PIN	TYCO / AMP
5	5	2	350689-1		CRIMP TERMINAL, FEMALE, AWG 18-24	TYCO / AMP
6	6	1	1-480698-0		CONNECTOR PLUG, UNIVERSAL MATE-N-LOK, 2 PIN	TYCO / AMP
7	7	2	350690-1		CRIMP TERMINAL, MALE, AWG 18-24	TYCO / AMP
8	8	1	794269-1		INTERFACE SEAL	TYCO / AMP
9	9	2	794270-1		WIRE SEAL	TYCO / AMP
10	10	2	2-520084-2		CONNECTOR, FASTON, AWG 18-22, .110 TAB WIDTH	TYCO / AMP
11	11	A/R			WIRE, 18 AWG, TINNED, ORANGE, 300V, PVC INSULATION	ANY SUITABLE MFR.
12	12	A/R			WIRE, 18 AWG, TINNED, RED/WHT (RED WITH WHITE TRACE), 300V, PVC INSULATION	ANY SUITABLE MFR.

VECTRIX VX-2 SERVICE MANUAL

SECTION F-2: CABLE ASSEMBLY-FRONT HEADLAMP/HORN + BOM

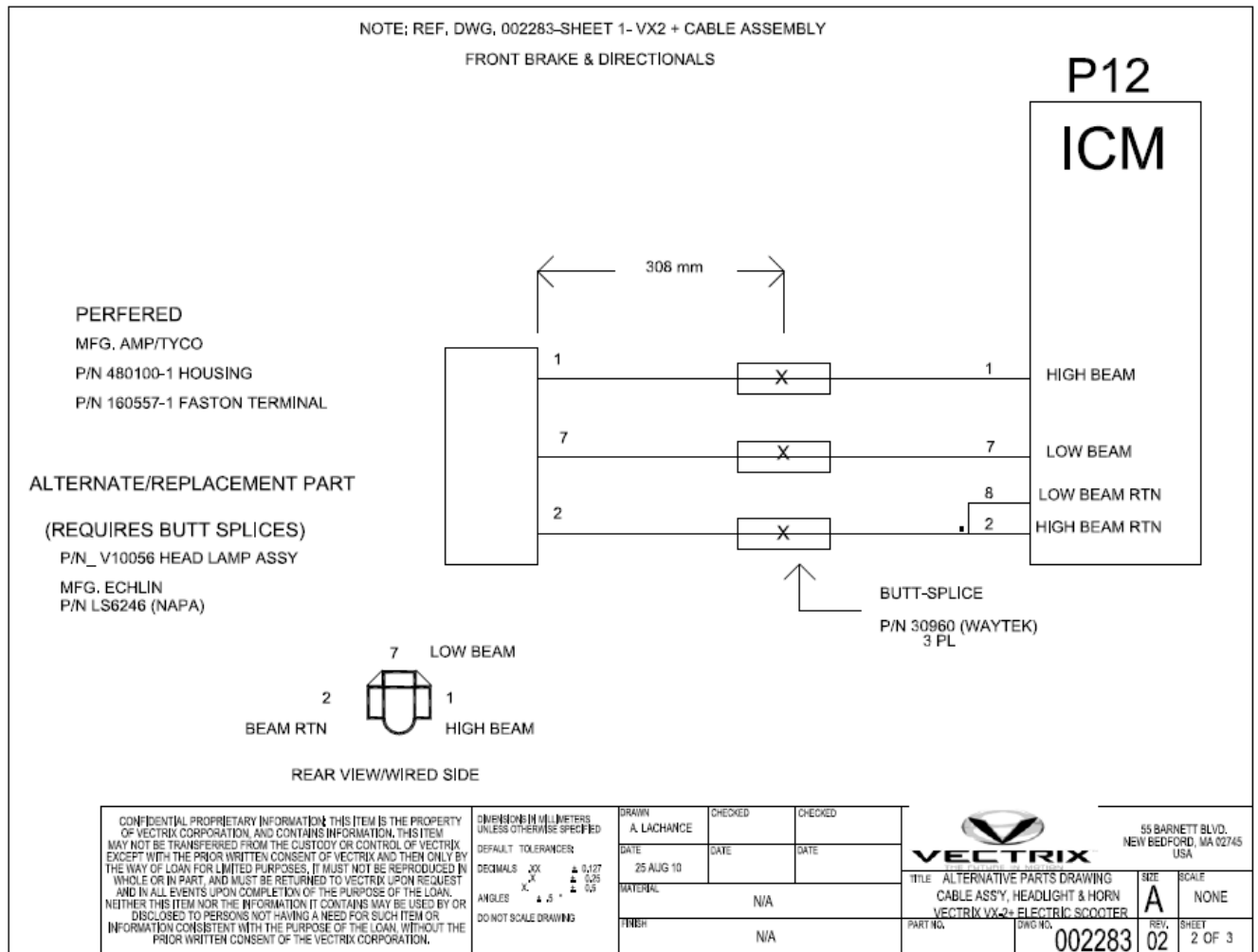

VECTRIX VX-2 SERVICE MANUAL

NOTES:

1. ALL NUMBERS IN BALLOONS REFERENCED ON SHEET 2 BOM.
2. FOLLOW WORKMANSHIP STANDARDS IN ACCORDANCE WITH IPC-620 OR IEC 60332-1
3. CRIMP IN ACCORDANCE WITH CONNECTOR MANUFACTURER'S SPECIFICATIONS.
4. WIRE GAUGE LISTED IN BOM.
5. CONNECTOR VIEWS SHOWN FROM WIRE ENTRY SIDE, WHERE APPLICABLE.
6. 1 REQ'D PER SCOOTER ASSEMBLY

REVISIONS		DWG NO.	002283
REV	DESCRIPTION	DATE	ECN NAME
01	RELEASED FOR PRODUCTION	11 JUN 10	VTRX-10978 PG
02	ADDED SHEET 2 WITH ALTERNATE/REPLACEMENT PARTS SPECIFIED	26 AUG 10	VTRX-10995 PG

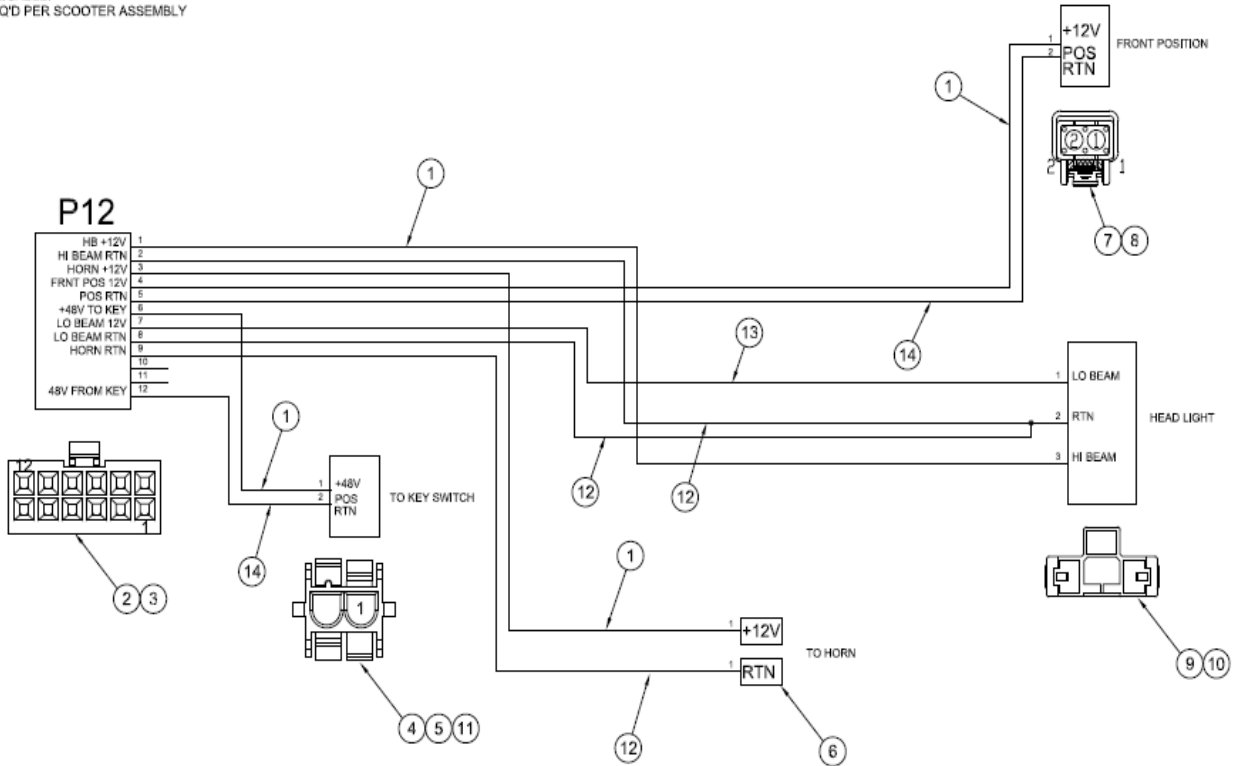

<p>CONFIDENTIAL PROPRIETARY INFORMATION: THIS ITEM IS THE PROPERTY OF VECTRIX CORPORATION AND CONTAINS INFORMATION THAT MAY NOT BE TRANSFERRED FROM THE CUSTODY OR CONTROL OF VECTRIX EXCEPT WITH THE PRIOR WRITTEN CONSENT OF VECTRIX AND THEN ONLY BY THE WAY OF LOAN FOR LIMITED PURPOSES. IT MUST NOT BE REPRODUCED IN WHOLE OR IN PART, AND MUST BE RETURNED TO VECTRIX UPON REQUEST AND IN ALL EVENTS UPON COMPLETION OF THE PURPOSE OF THE LOAN. NEITHER THIS ITEM NOR THE INFORMATION IT CONTAINS MAY BE USED BY OR DISCLOSED TO PERSONS NOT HAVING A NEED FOR SUCH ITEM OR INFORMATION CONSISTENT WITH THE PURPOSE OF THE LOAN, WITHOUT THE PRIOR WRITTEN CONSENT OF THE VECTRIX CORPORATION.</p>	<p>DIMENSIONS IN INCHES UNLESS OTHERWISE SPECIFIED</p> <p>DEFAULT TOLERANCES:</p> <p>DECIMALS .XXX ± 0.005</p> <p>FRACTIONS 1/16 ± 0.010</p> <p>ANGLES ± .5°</p> <p>DO NOT SCALE DRAWING</p>	<table border="1"> <tr> <td>DRAWN</td> <td>DATE</td> <td>CHECKED</td> <td>DATE</td> <td>DESIGNED</td> <td>DATE</td> </tr> <tr> <td>PAUL GAUDETTE</td> <td>07 JUN 10</td> <td></td> <td></td> <td></td> <td></td> </tr> </table>	DRAWN	DATE	CHECKED	DATE	DESIGNED	DATE	PAUL GAUDETTE	07 JUN 10					<p>VECTRIX</p> <p>55 SAMUEL BARNETT BLVD. NEW BEDFORD, MA 02745 USA</p>
	DRAWN	DATE	CHECKED	DATE	DESIGNED	DATE									
	PAUL GAUDETTE	07 JUN 10													
	<p>TITLE</p> <p>CABLE ASSEMBLY FRONT HEADLIGHT & HORN VECTRIX VX-2+ ELECTRIC SCOOTER</p>	<p>SCALE</p> <p>NONE</p>	<p>REV</p> <p>02</p>	<p>DRW NO.</p> <p>002283</p>											
<p>PART NO.</p> <p></p>	<p>REV</p> <p>C</p>	<p>SHEET</p> <p>1 OF 3</p>													

VECTRIX VX-2 SERVICE MANUAL

TITLE				REV.		
BOM-CABLE ASSEMBLY FRONT HEAD LIGHT & HORN VECTRIX VX-2+ ELECTRIC SCOOTER				02		
LINE No.	REFERENCE DESIGNATION	QTY	PART NO.	PACKAGE	PART DESCRIPTION	MFR
1	1	A/R			WIRE, AWG 18, TINNED, RED, 300V, PVC INSULATION	ANY SUITABLE MFR.
2	2	1	0039012120		CONNECTOR HOUSING, DUAL ROW, 12 PIN	MOLEX
3	3	10	39-00-0208		CRIMP TERMINAL, FEMALE SOCKET, AWG 18-24	MOLEX
4	4	1	1-480699-0		CONNECTOR HOUSING, UNIVERSAL MATE-N-LOK, 2 PIN	TYCO / AMP
5	5	2	350689-1		CRIMP TERMINAL, FEMALE, AWG 18-24	TYCO / AMP
6	6	2	2-520184-4		CONNECTOR, FASTON, AWG 18-22, .250 TAB WIDTH	TYCO / AMP
7	7	1	DT08-2S-E003		CONNECTOR HOUSING, 2 WAY	DEUTSCH
8	8	2	1082-16-0122		TERMINAL CRIMP, SOCKET, FEMALE AWG 18-18	DEUTSCH
9	9	1	172238-2		CONNECTOR, SEALED BEAM, POSITIVE LOCK, 3 POSITION	TYCO / AMP
10	10	3	170381-5		TERMINAL CRIMP, FEMALE	TYCO / AMP
11	11	1	794270-1		WIRE SEAL	TYCO / AMP
12	12	A/R			WIRE, AWG 18, TINNED, BLACK, 300V, PVC INSULATION	ANY SUITABLE MFR.
13	13	A/R			WIRE, AWG 18, TINNED, ORANGE, 300V, PVC INSULATION	ANY SUITABLE MFR.
14	14	A/R			WIRE, AWG 18, TINNED, RED/WHT (RED WITH WHITE TRACE), 300V, PVC INSULATION	ANY SUITABLE MFR.
9		1	490100-1		ALTERNATE PART FOR LINE ITEM 9	TYCO/AMP
10		3	180557-1		ALTERNATE PART FOR LINE ITEM 10	TYCO/AMP
9/10		1	LS6246		CONNECTOR ASSEMBLY	ECHLIN

VECTRIX VX-2 SERVICE MANUAL

SECTION F-3: CABLE ASSEMBLY-REAR BRAKE/INDICATORS/TAIL LIGHT/BATTERY/SIDE STAND + BOM

REVISIONS		DWG. NO. 002284		
REV	DESCRIPTION	DATE	SCN	MADE
01	RELEASED FOR PRODUCTION	11 JUN 10	VTR06-10875	PS

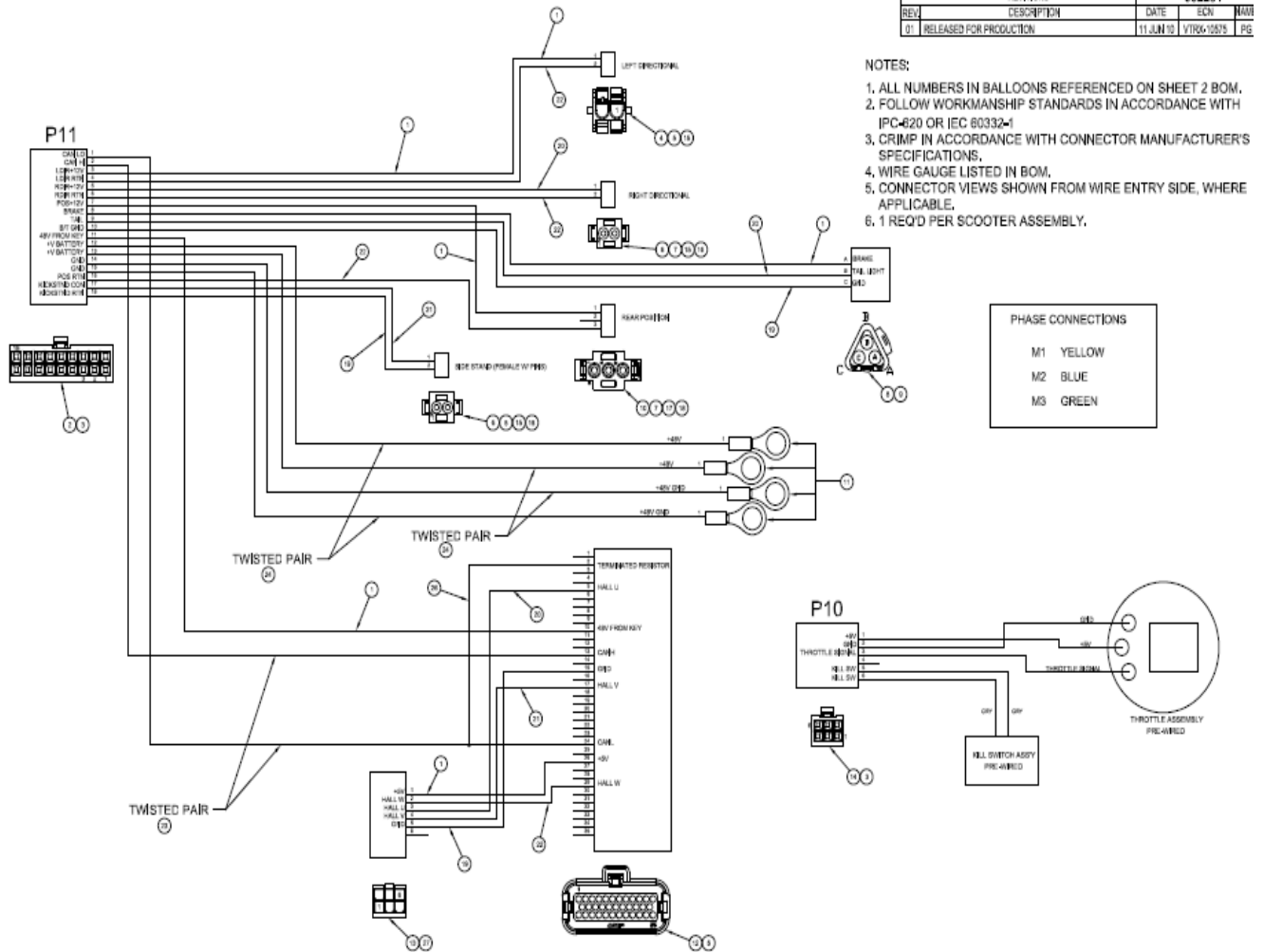

VECTRIX VX-2 SERVICE MANUAL

TITLE BOM-CABLE ASSEMBLY REAR BRAKE, DIRECTIONALS, TAIL LIGHT, BATTERY & SIDE STAND VECTRIX VX-2+ ELECTRIC SCOOTER					REV. 01	
LINE No.	REFERENCE DESIGNATION	QTY	PART NO.	PACKAGE	PART DESCRIPTION	MFR
1	1	A/R			WIRE, AWG 18, TINNED, RED, 300V, PVC INSULATION, UL1007 OR EQUAL	ANY SUITABLE MFR.
2	2	1	0039-01-2180		CONNECTOR HOUSING, MINI-FIT Jr., 18 PIN	MOLEX
3	3	18	39-00-0208		TERMINAL SOCKET, FEMALE, AWG 18-24	MOLEX
4	4	1	1-480-899-0		CONNECTOR HOUSING, UNIVERSAL MATE-N-LOK, 2 PIN	TYCO / AMP
5	5	11	350889-1		TERMINAL SOCKET, FEMALE, AWG 18-24	TYCO / AMP
6	6	2	1-480898-0		CONNECTOR HOUSING, UNIVERSAL MATE-N-LOK, 2 PIN	TYCO / AMP
7	7	2	350890-1		TERMINAL PIN, MALE, AWG 18-24	TYCO / AMP
8	8	1	DT06-3S-E003		PLUG ASSEMBLY, 3 WAY	DEUTSCH
9	9	3	1062-16-0122-PS		SOCKET, STAMPED AND FORMED	DEUTSCH
10	10	1	1-480700-0		CONNECTOR HOUSING, UNIVERSAL MATE-N-LOK, 3 PIN	TYCO / AMP
11	11	4	34151		RING AND SPADE TONGUE TERMINAL, M8	TYCO / AMP
12	12	1	776184-1		CONNECTOR HOUSING, PLUG ASSEMBLY, 35 PIN	TYCO / AMP
13	13	1	39-01-3069		CONNECTOR HOUSING, MINI-FIT Jr., 6 PIN, IN-LINE	MOLEX
14	14	1	39-01-2060		CONNECTOR HOUSING, MINI-FIT Jr., 6 PIN	MOLEX
15	15	3	794270-1		WIRE SEAL	TYCO / AMP
16	16	2	794269-1		INTERFACE SEAL	TYCO / AMP
17	17	1	794272-1		WIRE SEAL	TYCO / AMP
18	18	1	794271-1		INTERFACE SEAL	TYCO / AMP
19	19	A/R			WIRE, AWG 18, TINNED, BLACK, 300V, PVC INSULATION, UL1007 OR EQUAL	ANY SUITABLE MFR.
20	20	A/R			WIRE, AWG 18, TINNED, ORANGE, 300V, PVC INSULATION, UL1007 OR EQUAL	ANY SUITABLE MFR.
21	21	A/R			WIRE, AWG 18, TINNED, BLACK/WHITE, 300V, PVC INSULATION, UL1007 OR EQUAL	ANY SUITABLE MFR.
22	22	A/R			WIRE, AWG 18, TINNED, RED/WHITE, 300V, PVC INSULATION, UL1007 OR EQUAL	ANY SUITABLE MFR.
23	23	A/R			WIRE, AWG 22, 2 CONDUCTOR WITH DRAWIN WIRE, WHITE & BLACK, TWISTED PAIR, UL1007 OR EQUAL	ANY SUITABLE MFR.
24	24	A/R			WIRE, AWG 18, TINNED, RED & BLACK, TWISTED PAIR, 300V, PVC INSULATION, UL1007 OR EQUAL	ANY SUITABLE MFR.
25	25				WIRE SPLICE	ANY SUITABLE MFR.
26	26	A/R			WIRE, AWG 22, TINNED, BLACK, 300V, PVC INSULATION, UL1007 OR EQUAL	ANY SUITABLE MFR.
27	27	6	39-00-0121		TERMINAL SOCKET, MALE, AWG 18-24	MOLEX

VECTRIX VX-2 SERVICE MANUAL

SECTION F-4: TORQUE LIST FOR BOLTS/NUTS

Description	Force
Front axle self locking, nut	65 NM
Front brake housing on front shock , bolt	30 NM
Rear brake housing on rear fork, bolt	25 NM
Motor axle, nut	80 NM
Front shock, bolt	70 NM
Brake disc on front rim, bolt	25 NM
Brake disc on motor, bolt	15 NM
Ring on motor, bolt	15 NM
Handle bar, nut	50 NM
Rear fork, left and right nut	80 NM
Front fork, top nut, 32mm	60 NM
Rear shock, top bolt	45 NM
Rear shock, bottom nut	40 NM
Battery, bolt	25 NM
All plastic parts	16 kgf.cm

VECTRIX VX-2 SERVICE MANUAL

SECTION G-1: UNPACKING INSTRUCTIONS

VX-2 Unpacking Instructions



Remove the straps and the top of the cage to remove the bikes



VECTRIX VX-2 SERVICE MANUAL

In the trunk find the mirrors, splash guard, and handlebar weights



Add front fender, and rear splash guard as shown



VECTRIX VX-2 SERVICE MANUAL

Add handlebar weights and mirrors



Remove trunk liner to connect battery



VECTRIX VX-2 SERVICE MANUAL

Battery connected

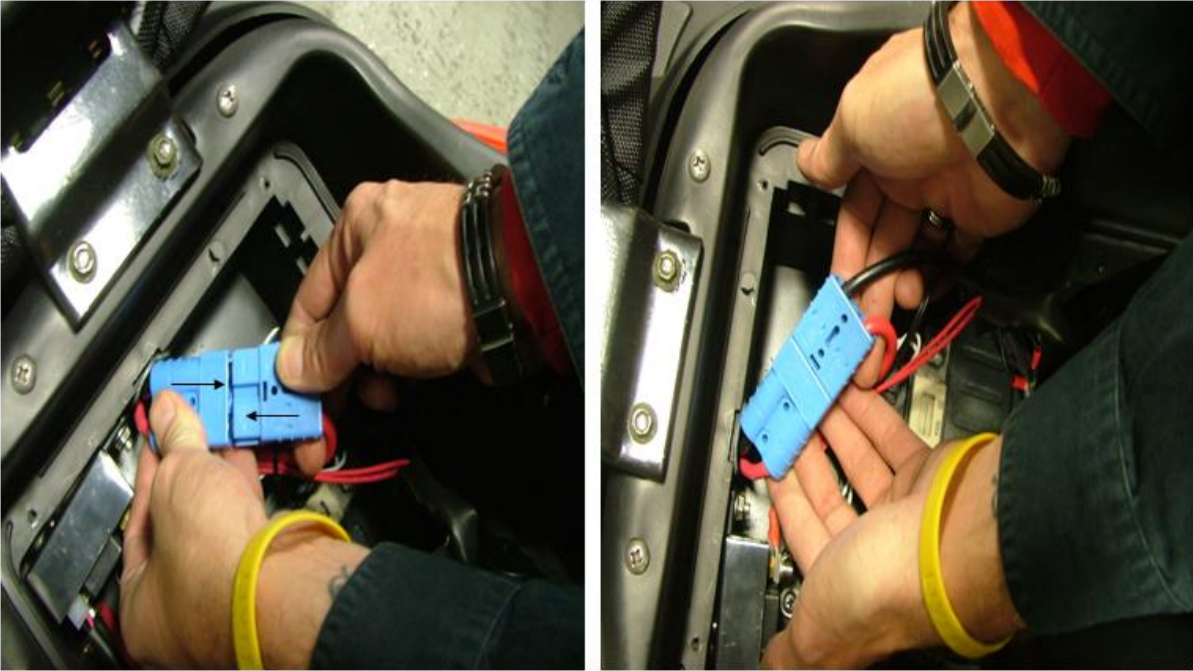

Remove charger from box & test,
then check the blinkers, tires, etc.



service@vectrix.com