

# Table Of Contents

---

<b>Introduction</b> .....	<b>1-1</b>	<b>Safety Information</b> .....	<b>2-1</b>
An Important Message To You From The Vectrix Family.....	1-1	General Safety Precautions .....	2-1
Introduction .....	1-1	Important Operating Information.....	2-2
Index.....	1-2	Location Of Important Labels.....	2-3
Useful Information For Safe Riding .....	1-2	<b>Controls And Components</b> .....	<b>3-1</b>
Plug in Your Scooter's Battery .....	1-2	Main Components.....	3-1
Owner Information .....	1-3	Front and Rear View.....	3-4
Motor Serial Number.....	1-4	Scooter Controls and Gauges .....	3-6
Key Code Number.....	1-4	Right Instrument Cluster .....	3-8
Vehicle Identification Number (VIN).....	1-4	Center Instrument Cluster .....	3-9
VIN Location .....	1-4	Left Instrument Cluster.....	3-10
General Information.....	1-5	Instrument Cluster Indicator Display.....	3-12
VX-1 Technical Specifications .....	1-5	Instrument Cluster Controls .....	3-15
Vehicle Range.....	1-8	Handlebar Controls.....	3-16
Frequently Asked Questions.....	1-8	<b>Starting And Operating</b> .....	<b>4-1</b>
Optimizing Your Range By Adapting Your Riding Style.....	1-10	General Operation .....	4-1
Emissions Information.....	1-10	Pre-Ride Inspection .....	4-1
Transporting.....	1-11	Key Switch/Steering Lock Positions.....	4-2
		Key Switch/Storage Positions.....	4-4
		Battery Charging.....	4-7

Charging the Battery .....	4-10	<b>Troubleshooting .....</b>	<b>6-1</b>
Operating Your Scooter.....	4-11	Troubleshooting.....	6-1
Rear Shock Adjustment.....	4-15	Brakes .....	6-1
Center Stand.....	4-16	Tires.....	6-1
Side Stand .....	4-17	General Troubleshooting.....	6-2
<b>Maintaining Your Scooter .....</b>	<b>5-1</b>	<b>Warranty/Customer Assistance .....</b>	<b>7-1</b>
Owner's Responsibilities .....	5-1	Customer Assistance.....	7-1
Battery.....	5-2	Warranty Information .....	7-2
General Maintenance .....	5-2	Warranty Registration .....	7-2
Brakes .....	5-2		
Suspension.....	5-4		
Wheels And Tires.....	5-5		
Replacement Tire Size .....	5-5		
Tire Wear Indicators (TWI).....	5-6		
Tire Inflation .....	5-6		
Lights.....	5-6		
Cleaning .....	5-7		
Parking And Long Term Storage .....	5-8		
Dealer Inspection.....	5-9		
Maintenance Schedule .....	5-10		
Vectrix Scooter Accessories.....	5-11		

## An Important Message To You From The Vectrix Family

Congratulations and thank you for purchasing the Vectrix VX-1 electric maxi scooter; we welcome you to the community of Vectrix Scooter riders. This manual is designed to provide you with a better understanding of the operation, inspection, and basic maintenance requirements of this scooter.

Vectrix continually seeks advancements in product design and quality. Therefore, this manual contains the most current product information available at the time of printing. Because of this, your scooter may differ from the information supplied in this owner's manual. No legal claims can be made on the basis of data in this manual. When it comes time to sell your Vectrix VX-1, please remember to hand over this manual; it is, by law, an important part of the vehicle. If you have any questions concerning the operation or maintenance of your scooter, please contact Vectrix at [service@vectrixscooters.com](mailto:service@vectrixscooters.com). For 24 hour updates and additional information about your scooter, visit the Vectrix Website: [www.vectrix.com](http://www.vectrix.com) in the USA or [info@vectrix europe.com](mailto:info@vectrix europe.com) in Europe.

## Introduction

Now you can leave the lumbering four-wheeler in the garage for those shorter trips, everywhere from across town to across campus.

VX-1 is the perfect machine for urban commuting, as well as freeway travel. It's also a natural for use with RVs, in retirement communities, and in large-scale venues like airports and convention centers. It has an impressive 136 km (85 mile) range that lets you zip past gas stations and even charging stations as you go.

The VX-1's easy-to-handle lower profile and lighter weight makes it perfect for any two-wheel rider. Its chassis has the responsiveness and maneuverability you need for tighter urban centers and congested traffic. And its advanced technology, intuitive controls, and solid, lightweight aircraft-aluminum frame construction makes it just as reliable and exciting as it is affordable.

## Index

A good place to locate information about the scooter is in the index in the back of the manual.

The terms “right” or “left” refer to the rider’s right or left when sitting on the scooter.

## Useful Information For Safe Riding

This manual contains the word **CAUTION** to communicate something that could hurt you or others. It also contains the word **WARNING** to communicate things that could damage your scooter.

**CAUTION:** Please read this manual carefully and completely before operating this scooter. Do not attempt to operate this scooter until you have attained adequate knowledge of its controls and operating features, and until you have been trained in safe and proper riding techniques. Regular inspections and proper maintenance, along with good riding skills, will help you to safely enjoy the capabilities and the reliability of this scooter. Disregarding the aforementioned, however, may render the warranty invalid.

## Plug in Your Scooter’s Battery

**WARNING:** Proper care of the scooter’s battery is essential! When not in use, the battery should be left on the charger even if fully charged. Failure to do so could damage the battery and therefore void your battery warranty. See page 4-7 for other important information about the battery.

## Owner Information

Record important information pertaining to your scooter here. When contacting your authorized Vectrix dealer, you may need to provide this information.

<b>Vehicle Identification Number (VIN)</b> <input type="text"/>	<b>Date of Delivery (Day/Month/Year)</b> <input type="text"/>
<b>Name:</b> _____	<b>Dealer Number</b> <input type="text"/>
<b>Street:</b> _____	
<b>City:</b> _____	<b>Dealer Stamp</b> <input type="text"/>
<b>State:</b> _____	
<b>Country:</b> _____	
<b>Postal Code:</b> _____	
<b>Telephone:</b> _____	
<b>Email:</b> _____	

## Motor Serial Number

The motor serial number is engraved on the bottom of the swingarm.

## Key Code Number

The key code is a number used to create duplicate keys. This number is located on a tag that accompanies the original keys.

## Vehicle Identification Number (VIN)

### VIN Location

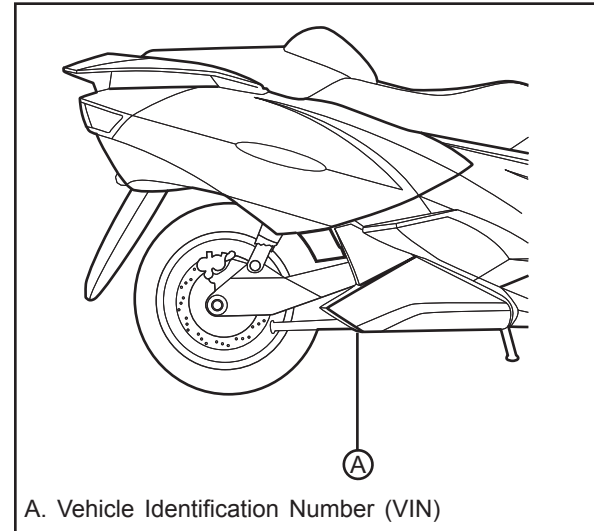

The VIN is located on the back lower corner of the frame. See Location Of Important Labels on page 2-3.

# General Information

## VX-1 Li/Li+ Technical Specifications

PERFORMANCE	
Maximum Speed	110 km/h (68 mph)
Maximum Reverse Speed	3 km/h (2 mph)
Acceleration	Li = 0-80 km/h (0-50 mph) in 6.0 seconds Li+ = 0-80 km/h (0-50 mph) in 6.25 seconds
Range	Li = up to 96 km (60 miles)* Li+ = up to 136 km (85 miles)*
Throttle	Patented Multi-Function Throttle provides regenerative braking and slow-speed reverse

\*Speed and range vary based on riding conditions and operation.

COMPONENTS	
Braking	Front and rear Brembo disc brakes
Tires	Pirelli: GTS23 120/70-14 (Front) Pirelli: GTS24 140/60-13 (Rear)
Front Fork	35 mm Marzocchi telescopic fork
Rear Suspension	Sachs twin shocks: preload adjustable
Chassis	Lightweight aircraft-aluminum frame
Battery	Lithium Iron Phosphate (LiFePO4)

<b>BATTERY</b>	
Capacity	Li= 3.7 kWh Li+= 5.4 kWh
Voltage	125V
Charger	1.5 kW on-board battery charger, 110-220V (50/60Hz)
Charge Time	Li= 3 to 4 hours Li+= 4 to 6 hours plus equalization, as needed
Discharge Cycles	Up to 1,600

<b>MOTOR GEARBOX</b>	
Motor Type	Brushless DC, radial air-gap rear-hub motor
Power	Peak power 21 kW (28.2 HP) at motor shaft
Torque	Maximum torque: 65 Nm (47.9 ft/lbs)
Gearbox	Integrated rear-wheel mounted planetary gear drive

<b>ELECTRONICS</b>	
Controller	DSP & IGBT based all-digital electronic control and motor drive system
Instrumentation	Central analog display and two side LCDs show speed, odometer, battery charge, estimated range and system status
Data System	Controller Area Network (CAN), Systems diagnostics and communication via laptop interface



<b>DIMENSIONS</b>	
Weight	Li = 193 kg (425 lbs) Li+ = 209 kg (460 lbs)
Wheelbase	1524 mm (60 in)
Seat Height	775 mm (30.5 in)
Storage Capacity	Trunk: 1.41 cu ft (1 full-faced helmet) Glove Compartment: .21 cu ft Optional Cargo Box: up to 1.66 cu ft
Carrying Capacity	2 passengers

<b>STORAGE (Maximum Load)</b>	
Trunk	12 kg (26 lbs)
Glove Compartment	2 kg (4 lbs)
Optional Cargo Box	9 kg (20 lbs)

<b>WARRANTY</b>	
Warranty	24 months

<b>EMISSIONS</b>	
Emissions	Pollutants: Zero CO2: Zero Exhaust Noise: Zero

<b>WEIGHT</b>	
Gross Vehicle Weight Rating (GVWR)*	425 kg (938 lbs)
Gross Axle Weight Rating (GAWR) Front**	153 kg (338 lbs)
Gross Axle Weight Rating (GAWR) Rear**	272 kg (600 lbs)

\* The Gross Vehicle Weight Rating (GVWR) is the combined weight of the scooter, passengers and cargo.

\*\* The Gross Axle Weight Rating (GAWR) is the maximum allowable weight that can be placed on an individual axle.

## Vehicle Range

The range of an electric vehicle is defined as the distance the vehicle will travel on a single full charge of the battery. Just like EPA mileage estimates for an automobile, “your mileage may vary.” Your range results are a direct reflection of your riding habits. The more conservative you ride the better range you can expect from your Vectrix VX-1 scooter.

Some of the factors which affect range include speed, acceleration, number of starts and stops, as well as changes in elevation and temperature. The combination of these factors, as you travel from one point to another, defines your trip profile. In addition, tire pressure and payload are important considerations.

We suggest that you ride conservatively when you first get your Vectrix VX-1 scooter, and get to know your scooter and your commute. Once you become familiar with the range versus performance of your scooter, you can adjust your riding characteristics if you so desire. This applies mainly to riders with trip profiles which are at the edge of the performance envelope. Those individuals with relatively short commutes can expect to ride quite aggressively and reach their destination with energy to spare.

## Frequently Asked Questions

### *Does Acceleration Affect Range?*

Yes, acceleration is the rate at which you are attempting to increase the speed of your scooter. The greater the acceleration the faster you are depleting the energy in the battery pack. The harder and more frequently you accelerate the more adversely you will affect the range of your scooter. Being “first off the line” means you will also be the first to deplete your energy supply.

**Hard Acceleration = Reduced Range**

### *Does Weight Affect Range?*

The more mass you are pushing/lifting, the more energy it takes to accomplish the mission. Avoid keeping unnecessary items in your scooter since it will impact your range.

**Added Weight = Reduced Range**

### ***Why Do I Get Less Range At Higher Speeds?***

It takes more power to push a Vectrix faster because you encounter aerodynamic resistance. The faster you attempt to travel, the more important this factor becomes. Energy (kWh) is power (watts) integrated over time. Also, it is a fundamental characteristic of battery energy storage systems that the amount of energy you are able to extract (usable energy) is inversely proportional to the rate at which you draw out the energy. If a battery pack is rated for 30 Ah, if you draw 10 amperes of current, you will deliver more energy than if you are drawing 100 amperes of current. Bottom line is that the more conservative you drive, the further you will travel on a single charge.

**Faster Speed = Reduced Range**

### ***How Does Tire Pressure Affect Range?***

As the scooter is ridden, heat is generated in the tires from deformation at the contact patch. Higher inflation pressure reduces the deformation, which results in reduced heating of the tire and reduced energy loss. A tire that is at 2/3 of the proper inflation pressure will have as much as 30% greater rolling resistance than a tire inflated to the specified pressure. This difference can easily be felt when moving the scooter manually. More force is required to move the scooter when tire pressure is low. Keep the tires inflated to the specified pressure to maximize range.

**Incorrect Tire Pressure = Reduced Range**

## Optimizing Your Range By Adapting Your Riding Style

- Apply the throttle slowly and try to match the scooter's acceleration with your throttle position.
- Hard acceleration will decrease your range.
- Coasting whenever possible makes a significant difference. The regenerative (regen) braking system on deceleration takes some of the energy from the motor and turns it back into electrical energy. This energy is then transferred to the battery. Use the regen braking whenever safely possible to increase your range.
- Plan ahead for decelerations and coast whenever possible. For example, do not rush to traffic signals.

## Emissions Information

The Vectrix VX-1 electric scooter is a Zero Emissions Vehicle (ZEV) under California Air Resources Board (CARB), U.S. Federal (EPA), and European Union standards. It uses no gasoline or other liquid fuel. It has no tailpipe and therefore, no tailpipe emissions. It also has no exhaust or evaporative emissions. Since the Vectrix VX-1 runs solely on electricity, it is the only kind of vehicle which actually gets cleaner in terms of air pollution each year, as the electrical grid gets cleaner and more renewable.

**WARNING:** Please use only Vectrix approved parts and accessories for your Vectrix scooter. Parts and accessories for your Vectrix scooter have been checked and tested for safety and suitability. Vectrix is unable to accept any liability whatsoever for parts and accessories which have not been approved.

## Transporting

**WARNING:** Take special care of the rear brake hose. Do not crush or place the ratchet strap over or on the brake hose. Doing so could cause possible damage and may result in an unsafe condition.

It is recommended that the scooter be tied-down using ratchet straps. Soft straps must be used to prevent scratches or other damage.

### Front:

D-rings (A) are located on each side of the front fork.

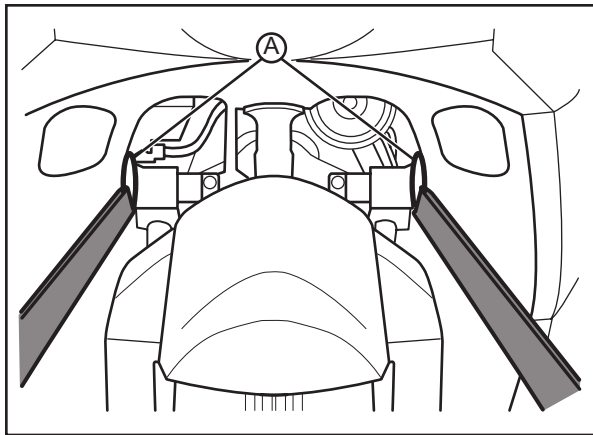

### Rear:

A protective cloth should be wrapped around the motor side swingarm to prevent damage to the ratchet strap.

### Left Side:

Install the ratchet strap (B) around the motor side swingarm.

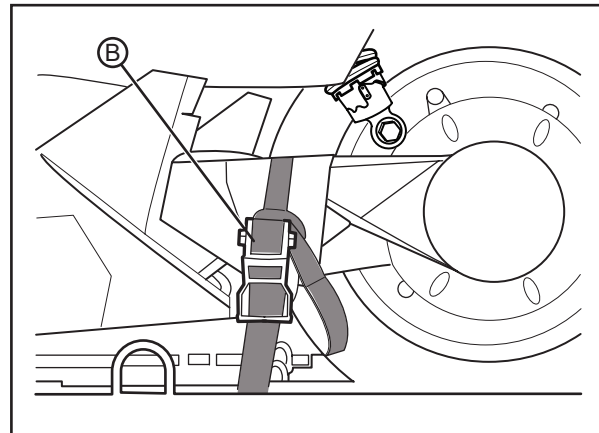

**Right Side:**

Carefully install the ratchet strap (C) under the rear brake hose and around the brake side swingarm. Do not pull on the rear brake hose as this could weaken the connection.

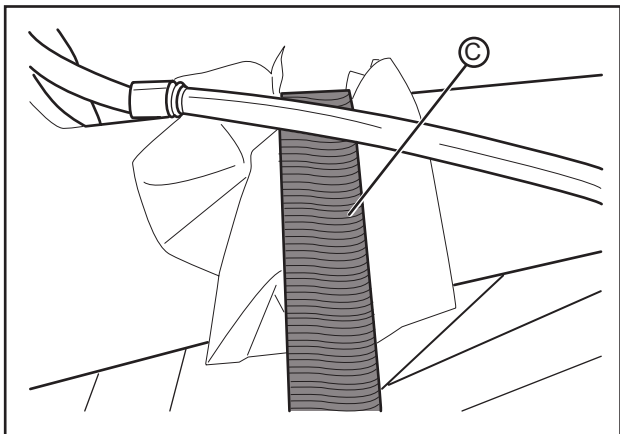

## General Safety Precautions

1. This is a performance scooter and should be treated with extreme caution.
2. Proper safety gear, including a regionally approved helmet, riding boots, gloves, and protective clothing should be worn while riding to reduce the risk of potential injury. We highly recommend the use of full height riding boots since the vast majority of scooter injuries are leg and foot injuries. It is not recommended to ride without protective clothing; this applies to even short journeys, and for every season of the year.
3. Under some conditions, open or loose clothing can have an adverse affect on driving safety.
4. Read all additional warnings and product instructions in this owner's manual, as well as safety labels, before operating the electric scooter.
5. Always keep both hands on the handlebars while riding. When riding around bends, the rider and passenger (when applicable) should lean with the scooter into the curve.
6. Never permit a guest to ride your electric scooter without proper instruction. These are performance scooters and should be treated with extreme caution.
7. Do not ride on frozen, oily, or pitted surfaces. Avoid potholes, surface cracks, and other obstacles. Use additional caution when riding on poor or wet surfaces. This scooter is not intended for off-road use.
8. Never use alcohol or drugs before or when operating an electric scooter.
9. Persons unwilling or unable to take responsibility for their actions should not use this scooter. You assume all responsibility while operating your scooter. The seller will assume no liability for misuse or operator negligence.
10. Prior to each use, the rider must check the charge level of the battery as indicated on the right instrument cluster display.

11. Your safety depends in part on the good mechanical condition of the scooter. Be sure to follow the maintenance schedule and adjustment requirements contained in this manual. Be sure you understand the importance of checking all items thoroughly before riding.
12. Modifications of the scooter may render the vehicle unsafe and may cause severe personal injury. Vectrix cannot be held liable for non-approved modifications.
13. Be very careful when loading or adding accessories to your scooter. Large, bulky, or heavy items may adversely affect the handling and performance of your scooter.
14. Failure to follow battery storage and charging instructions, as described in this Vectrix VX-1 Owner's Manual, may void the warranty of your Vectrix scooter. These guidelines have been rigorously tested to ensure maximum battery efficiency and service.

## Important Operating Information

1. Always turn the key switch/power ON/OFF switch to the OFF position when not actively riding. It is very easy to forget that the scooter is powered up because it is silent. An accident can occur if the scooter is left powered up while getting on or off the scooter.
2. Turn the key switch OFF when backing up or pushing the scooter while dismounted. It is possible to unintentionally twist the throttle, resulting in unexpected acceleration.
3. Use the rear brake when you are stopped on an incline. **Do not hold the scooter using partial throttle or damage to the motor may occur.**
4. Keep your Vectrix VX-1 connected to the battery charger when your scooter is sitting in storage or if it will be sitting unused for more than one month.

**WARNING:** Charge the Vectrix battery with only the Vectrix supplied charger. Use of any other charger may cause a safety issue and will void the warranty.



The battery must be charged within 24 hours if fully discharged, and charged within one month if stored fully charged. Vectrix recommends that you plug in your Vectrix scooter after one month even if charged. Please leave your Vectrix scooter plugged in whenever possible.

5. The battery does not require or tolerate deep discharging. To get the most battery life, recharge the battery immediately after each ride. Leaving the battery in a discharged state will cause damage and may void the warranty. See Charging The Battery on page 4-10.

## Location of Important Labels

### Vehicle Identification Number (VIN)

The VIN (A) is located on the back lower corner of the frame.

#### USA:

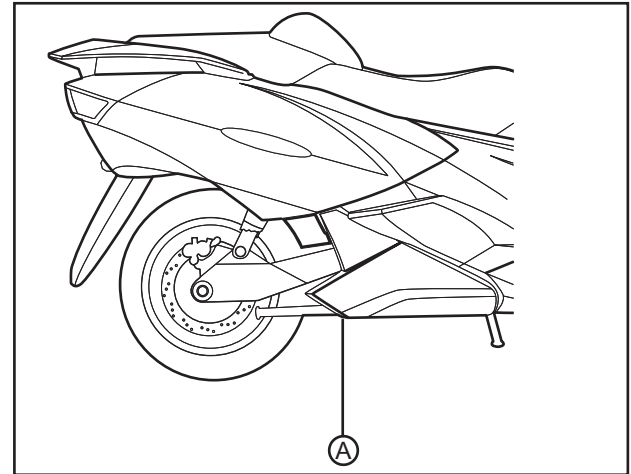

## Europe:

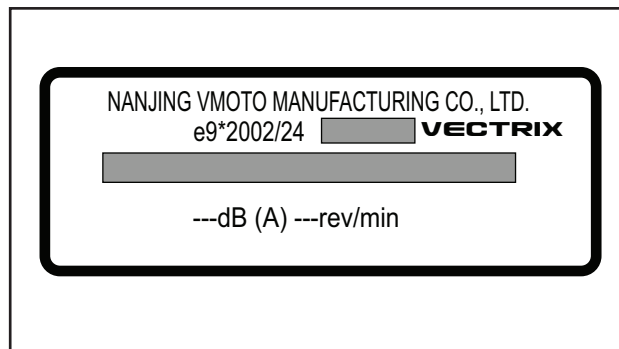

## Manufacturer's Data Plate

This plate is located across from the VIN. It displays the VIN (upper section), manufacturer's name, type approval mark, the VIN printed again (lower section) and the static sound level.

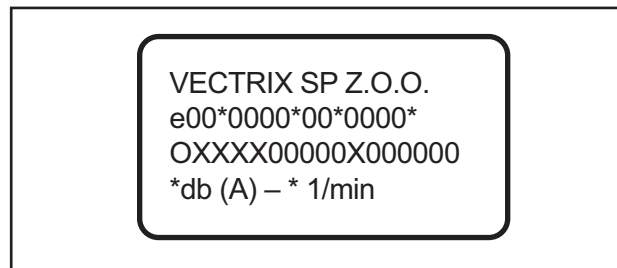

## Department of Transportation (DOT) Label

The DOT certification label (B) is located on the front of the scooter, behind the front wheel well (U.S. markets only).

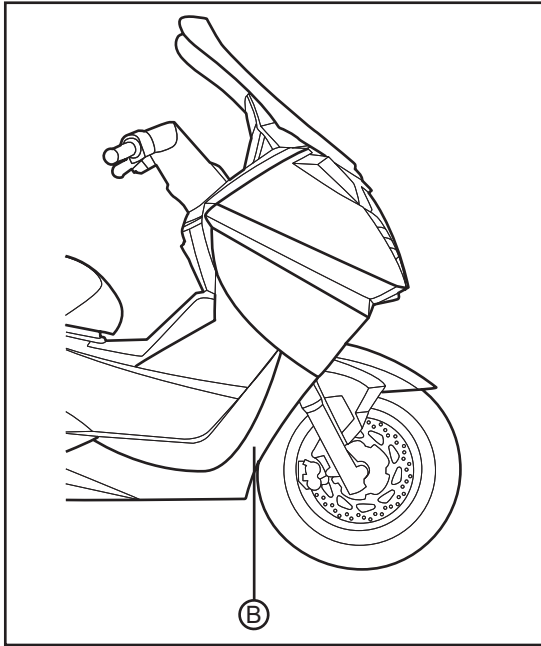

## DOT Label:

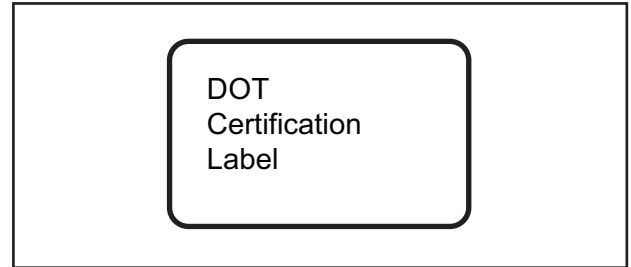

A. The accessory port notice label is located on the inside of the glove compartment door.

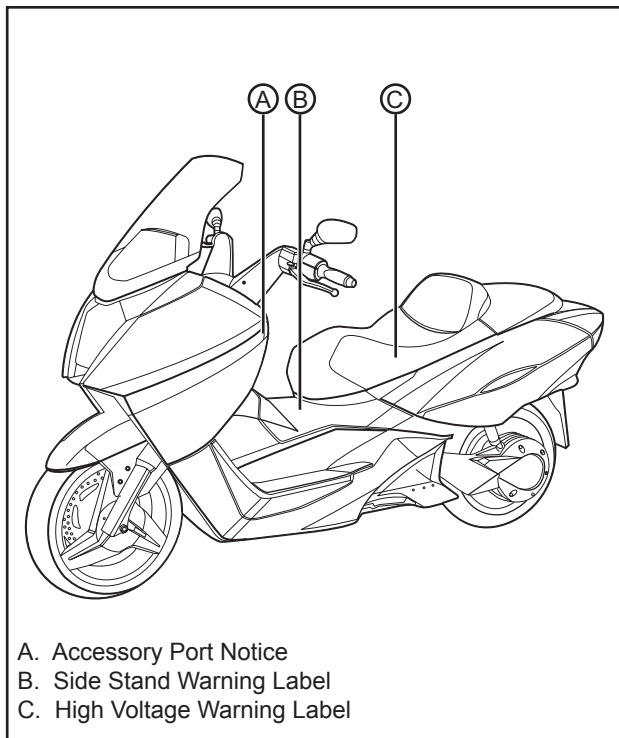

### NOTICE

Accessory Port  
12 VDC 0.5 AMPS (6 WATTS)  
MAXIMUM

B. The side stand warning label is located in the step through area in front of the seat.

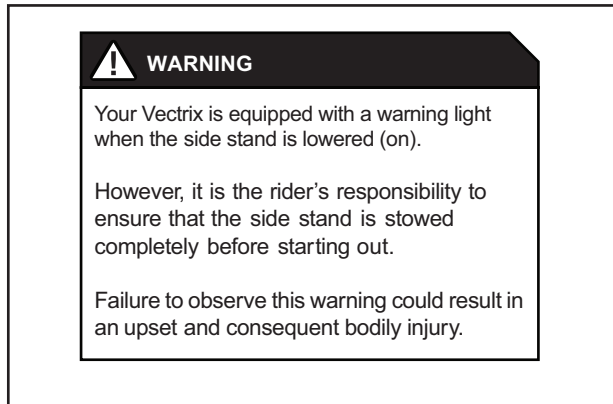

C. The high voltage warning label is located under the driver's seat.

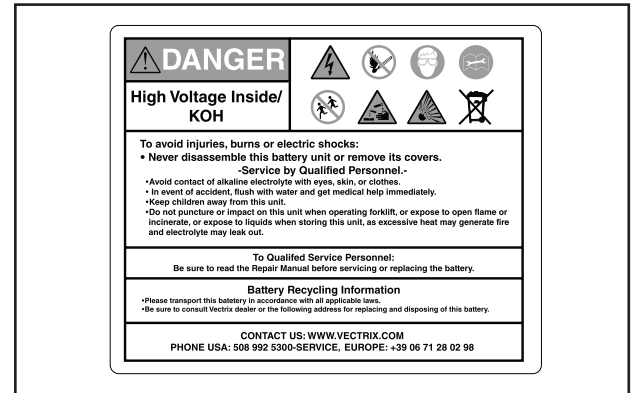



## Main Components

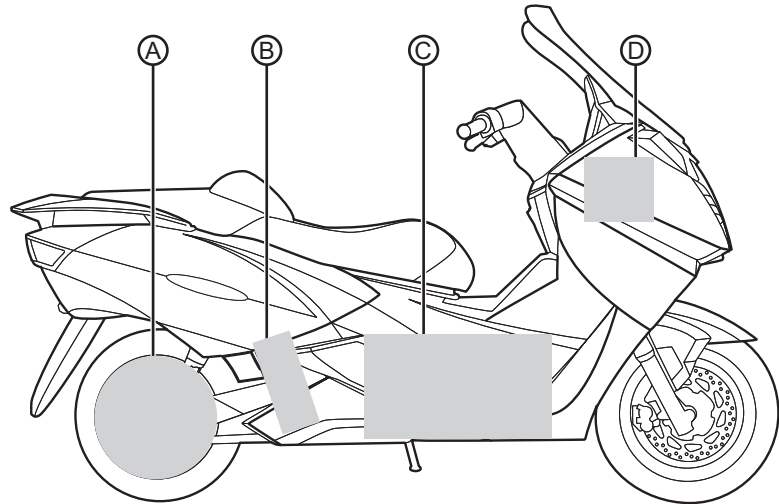

- A. Planetary Gearbox/  
Brushless DC Motor/Encoder
- B. Motor Controller
- C. Battery Pack
- D. Battery Charger

## A. Planetary Gearbox/Brushless DC Motor/Encoder

### • Planetary Gearbox

This single stage gearbox is mounted to the rear wheel and is permanently sealed and lubricated so that it requires no maintenance. The gearbox is vented by means of a small vent cap located on the top side of the motor. For vent cap maintenance see page 5-4.

### • Brushless DC Motor

The brushless DC motor is mounted in the left side of the swingarm. The motor shaft is connected to the gearbox in the rear wheel.

### • Encoder

The encoder is located behind a sealed cover that is under the swingarm chrome cover, on the left side of the swingarm. Do not remove the sealed cover. This cover seals out dirt and moisture, protecting the adjustment to the encoder.

## B. Motor Controller

The motor controller is the “brain” of the scooter, providing the interface between the battery pack and the motor. It is located just behind the battery pack.

Only your authorized Vectrix dealer is qualified to troubleshoot the motor controller.

**WARNING:** Removal of the cover and/or modification of the motor controller by any means will void the warranty and is extremely hazardous.

## C. Battery Pack

### **CAUTION:**

Opening battery pack is dangerous and can cause injury or death from electrocution. **DO NOT OPEN!** Opening the battery pack will void your warranty. Only your authorized Vectrix dealer is qualified to troubleshoot a battery related issue.

Proper care of your battery pack is essential for maximum performance. Maximum performance is reached after you have performed five (5) initial charge/deep discharge cycles. Each initial deep discharge/charge will improve your range.

The battery pack must be kept within a preset operating temperature window. The battery system includes fans that draw outside air through the battery pack. These cooling fans are turned on in response to temperature, or when you are charging the battery.



The battery pack consists of two boxes located within the scooter frame. The battery pack weighs approximately Li = 51 kg (112 lbs) or Li+ = 65 kg (143 lbs). The battery pack is connected to the motor controller through a 125 amp fuse. This fuse is only accessible by your authorized Vectrix dealer.

Occasionally the estimated range and the battery level indicator may drop from a few kilometers/miles and a few bars, to zero. This means the charger memory and battery level need to be synchronized. See Troubleshooting section for more information on synchronization. If the “drop off” continues to happen on a regular basis, this may indicate a problem with the battery and you should contact your authorized Vectrix dealer.

#### D. Battery Charger

The battery charger is integrated into the scooter and is located behind the front right fairing panel. It monitors the status/condition of the battery pack during normal operation as well as charging. The battery pack is an integrated system of temperature/voltage monitoring as well as cooling air flow control.

## Front and Rear View

- A. Right Front Turn Signal Light
- B. Headlight/Daytime Running Light
- C. Left Front Turn Signal Light
- D. Left Rear Turn Signal Light
- E. License Plate Light
- F. Tail/Brake Light
- G. Right Rear Turn Signal Light
- H. Passenger Grab Handle

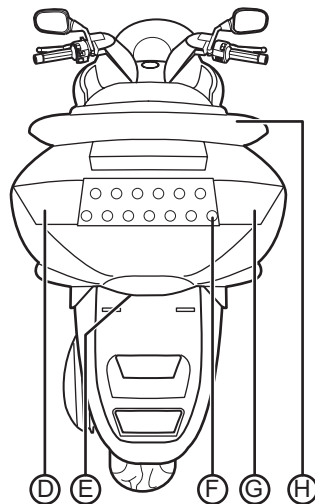
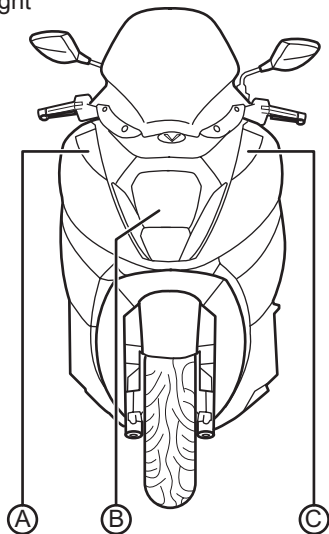

A.,G. Right Side Turn Signal Lights

These lights will flash anytime the key switch is in the ON position and the turn signal switch is moved to the right. The instrument cluster indicator display right turn signal indicator will also flash.\*

B. Headlight

The headlight contains a dual filament high/low beam 35 watt halogen bulb and an LED daytime running light.\*

C.,D. Left Side Turn Signal Lights

These lights will flash any time the key switch is in the ON position, and the switch is moved to the left. The instrument cluster indicator display left turn signal indicator will also flash.

E. License Plate Light

This light will illuminate any time the key switch is in the ON position.\*

F. Tail/Brake Light

The tail light will illuminate any time the key switch is in the ON position. The brake light will illuminate any time either the front or rear brake levers are squeezed.\*

H. Passenger Grab Handle

A passenger should have his or her hands on the grab handle or wrapped around the driver at all times when the scooter is in motion.

This handle is also used for setting the scooter on the center stand. It is not, however, intended to be used to lift the scooter.

\*These are extreme long-life light emitting diode (LED) lighting systems. See your authorized Vectrix dealer for replacement of these lighting systems.

## Scooter Controls and Gauges

- A. Left Handlebar Control
- B. Instrument Cluster Controls
- C. Left Instrument Cluster
- D. Instrument Cluster Indicator Display
- E. Center Instrument Cluster
- F. Right Instrument Cluster
- G. Key Switch
- H. Right Handlebar Control

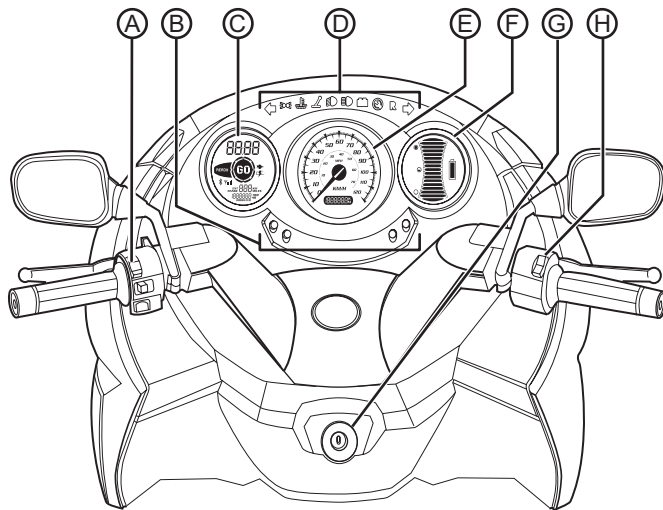

Indicators and gauges can signal that something is wrong before it becomes serious enough to cause an expensive repair or replacement.

Malfunction indicators come on when there is, or may be, a problem with one of your scooter's functions. Some indicators come on briefly when you turn the key switch ON just to let you know they are working. Once you are familiar with this section, you should not be alarmed when this happens.

When one of the indicators comes on and stays on as you are riding, or when one of the gauges shows there may be a problem, check the section that tells you what to do about it. Please follow this manual's advice. Waiting to do repairs can be costly and even dangerous. Please get to know your scooter's indicators and gauges; they can be a big help.

- A. Left Handlebar Control  
See Handlebar Controls on page 3-16.
- B. Instrument Cluster Controls  
See Instrument Cluster Controls on page 3-15.
- C. Left Instrument Cluster  
See Left Instrument Cluster on page 3-10.
- D. Instrument Cluster Indicator Display  
See Instrument Cluster Indicator Display on page 3-12.
- E. Center Instrument Cluster  
See Center Instrument Cluster on page 3-9.
- F. Right Instrument Cluster  
See Right Instrument Cluster on page 3-8.
- G. Key Switch  
For description and operation see page 4-2.
- H. Right Handlebar Control  
See Handlebar Controls on page 3-16.

## Right Instrument Cluster

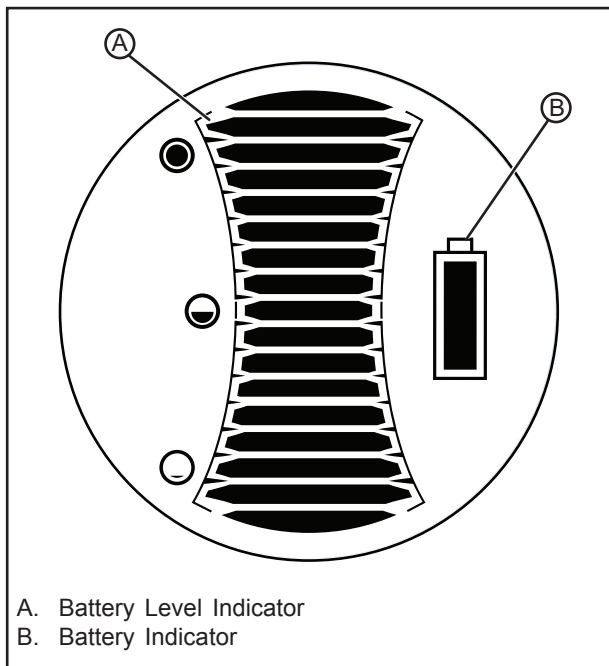

- A. Battery Level Indicator  
The battery level indicator is a 17-bar graphic gauge that displays the remaining battery charge.
- B. Battery Indicator  
This indicates that the scooter is running on the battery.

## Center Instrument Cluster

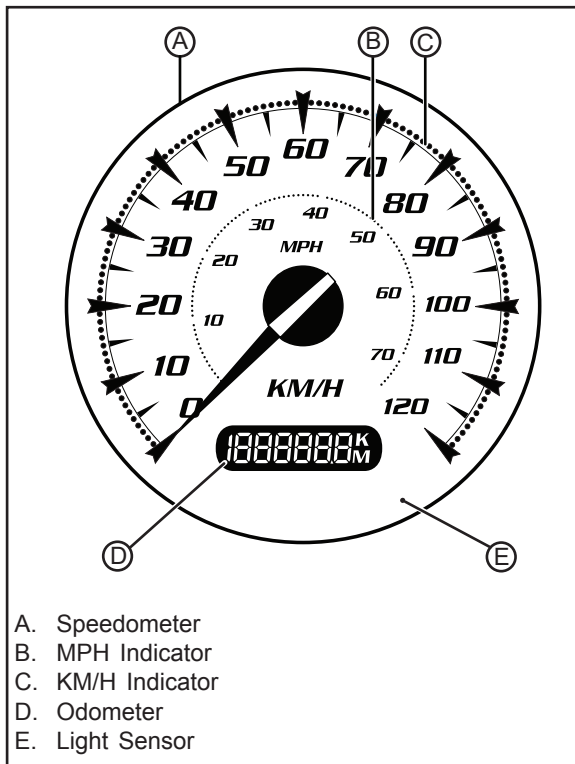

- A. Speedometer  
The speedometer displays your current speed. During the charging process, the speedometer indicates the charge current times 10. Example: If the KM/H meter reading is 100 KM/H, the charge current is 10 amps.
- B. MPH Indicator  
This indicator displays your current speed in miles per hour.
- C. KM/H Indicator  
This indicator displays your current speed in kilometers per hour.
- D. Odometer  
The odometer reading lets you see how many total miles or kilometers you have traveled on your scooter. During the charging process, the odometer will indicate the charge mode and the charge termination voltage. Charging modes are:
- CP - Constant Current
  - CV - Constant Voltage
  - EC - End of Charge
  - DE - Delay Mode
- See Battery Charging on page 4-7 for more information. If the “Maintenance Required” indicator (wrench) is illuminated this will display an abbreviated fault code.

### E. Light Sensor

The light sensor detects the level of ambient light and adjusts the liquid crystal display (LCD) backlighting of the left, center, and right instrument clusters.

## Left Instrument Cluster

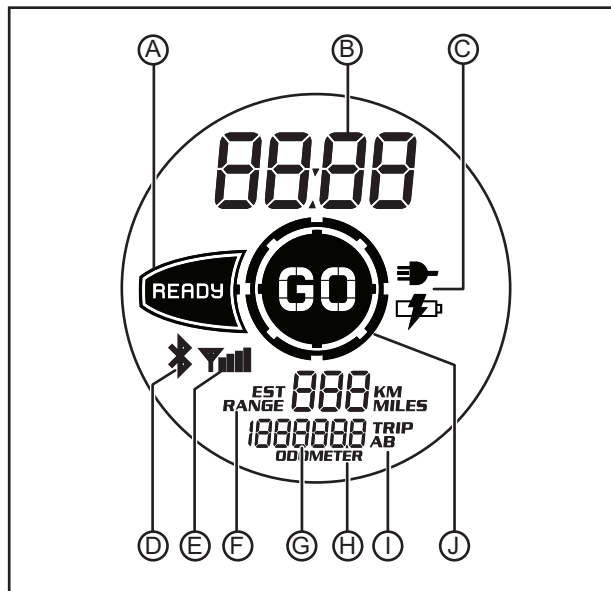

### A. Ready Indicator

### B. Clock Reading Display

### C. Battery Charge/Charging Indicator

### D. Bluetooth Indicator

### E. RF Range Indicator

### F. Estimated Range Display

### G. Trip Odometer Display

### H. Odometer/Trip A-B Display

### I. Odometer/Trip A-B Display Setting

### J. GO Indicator

### A. Ready Indicator

This indicator is illuminated when the system is ready to be enabled.

### B. Clock Reading Display

This displays the time of day in either 12 or 24 hour format. This will also display the total charge time during charging or the remaining cool down time during the delay charging mode.

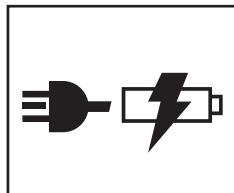

### C. Battery Charge/Charging Indicator

This indicator will illuminate when the system is being charged by an external power source.



- D. Bluetooth Indicator  
Not Used. In place for future enhancements.
- E. RF Range Indicator  
Not Used. In place for future enhancements.
- F. Estimated Range Display  
This displays the estimated range available (km or miles) based on your recent driving profile. Hard accelerations and high speeds will decrease this value; soft accelerations and slower speeds will increase this value. During the charging process this displays the battery voltage.
- G. Trip Odometer Display  
You can display individual trip mileage in either kilometers or miles. It can be reset by pressing the “S” on the instrument cluster controls.  
See Instrument Cluster Controls on page 3-15.
- H. Odometer/Trip A-B Display  
This displays the mileage of the currently selected trip or odometer. Use the instrument cluster control button marked “E/M” to switch the display values between km or miles. During the charging process this will display the highest battery module temperature in C°.
- I. Odometer/Trip A-B Display Setting  
This indicates the mileage reading currently displayed. Use the instrument cluster control button marked “S” to switch between Trip A, Trip B or the odometer.
- J. GO Indicator  
This indicator will illuminate when the system is enabled and ready to accelerate.

## Instrument Cluster Indicator Display

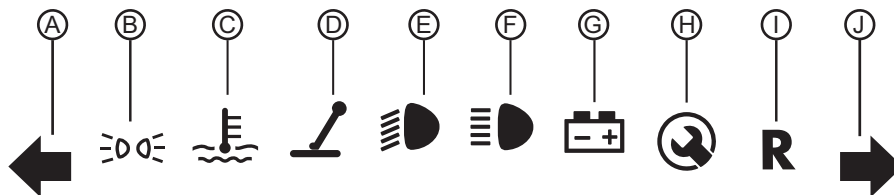

- A. Left Turn Signal
- B. Parking/Position Lamps
- C. High Temperature
- D. Side/Center Stand
- E. Low Headlight Beam
- F. High Headlight Beam
- G. Battery
- H. Maintenance Required
- I. Scooter Reverse
- J. Right Turn Signal

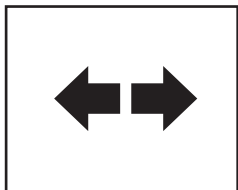

- A.,J. Turn Signals  
An arrow on the indicator display will flash green in the same direction selected by the turn signal switch. This will remain on until the turn signal request has been cancelled. If the arrow indicator is on solid, the turn signal is not functioning.

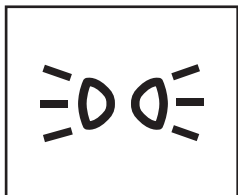

- B. Parking/Position Lamps  
This indicator will illuminate green when the position lights are on and working correctly. A flashing indicator alerts you that one or both are not working.

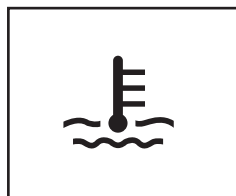

- C. High Temperature  
This indicator will illuminate red in the unlikely event you exceed the scooters performance capabilities. This indicator senses the battery and other key system components' temperature.

**WARNING:** The scooter will continue to operate, but at a reduced performance level. Continuing to operate the scooter could result in permanent damage. In many cases, allowing the scooter to cool will correct the condition. If this indicator is flashing, see Troubleshooting on page 6-1.

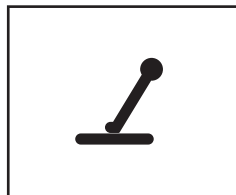

- D. Side/Center Stand  
This indicator will illuminate amber when the side stand is down or lowered. The scooter will not operate when the side stand is down or lowered. The scooter can only be "enabled" when the side stand is in the up position.

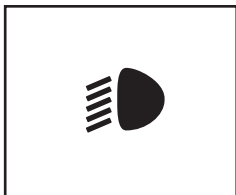

- E. Low Headlight Beam  
This indicator will illuminate green when the headlight low beam is selected and operational. If the headlight is not functional, the indicator will flash. See Troubleshooting on page 6-1.

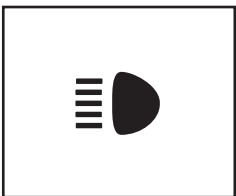

- F. High Headlight Beam  
This indicator will illuminate blue when the headlight high beam is selected and operational. If the headlight is not functional, the indicator will flash. See Troubleshooting on page 6-1.

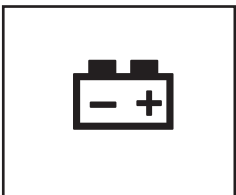

- G. Battery  
This indicator will illuminate when the battery voltage is low, indicating that it is time to charge the battery. Performance and range are limited. If the indicator is still illuminated after charging, contact your authorized dealer.



- H. Maintenance Required  
This indicator will illuminate amber. If this indicator is illuminated you should contact your authorized dealer.



- I. Scooter Reverse  
This indicator will illuminate amber when the scooter is in reverse. Twisting the throttle control clockwise (forward) will move the scooter in a low speed reverse.

## Instrument Cluster Controls

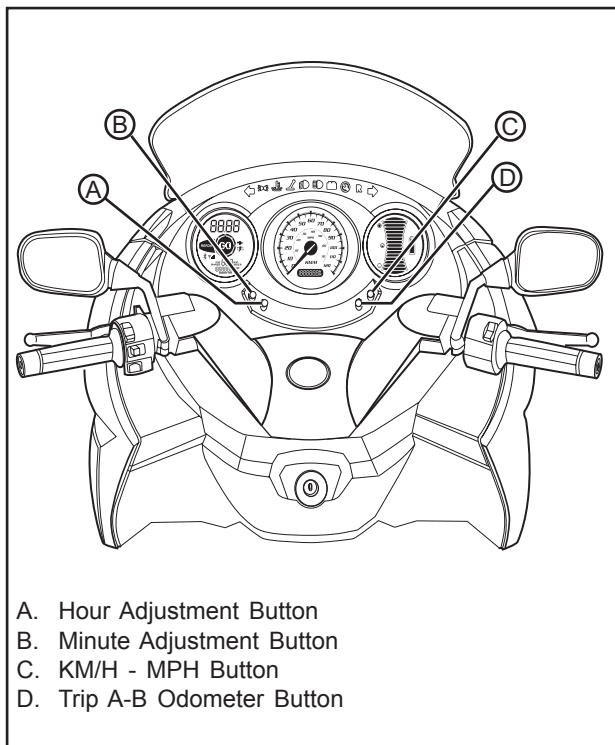

- A. Hour Adjustment  
This button is labeled with an "H." It allows you to change the hour on the clock. Push this button in order to change the hour. Pressing down on the button and holding for 3 seconds will allow you to choose from 12 or 24 hour formats.
- B. Minute Adjustment  
This button is labeled with an "M." It allows you to change the minutes on the clock. Push this button in order to change the minutes.
- C. KM/H - MPH  
This button is labeled with a "E/M." Pressing it allows you to change between kilometers and miles. The current setting will be displayed on the left instrument cluster. The factory default setting is kilometers.
- D. Trip A-B Odometer  
This button is labeled with an "S." Pressing it allows you to scroll between Trip A, Trip B, or the normal odometer reading. You can reset Trip A or Trip B by scrolling to the desired trip then pressing and holding the button for 3 seconds.

## Handlebar Controls

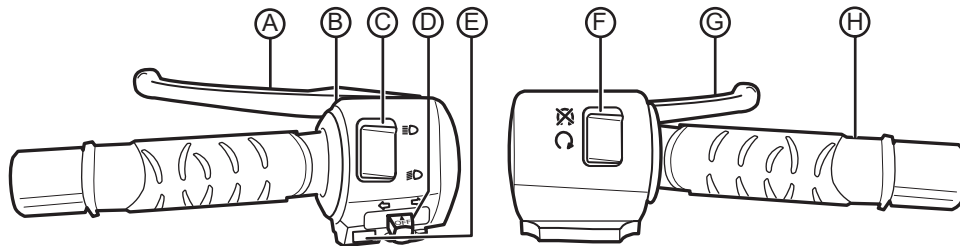

- A. Rear Brake Lever
- B. High Beam Flash-To-Pass Switch
- C. Headlight High/Low Beam Switch
- D. Turn Signal Switch
- E. Horn Button
- F. Power ON/OFF Switch
- G. Front Brake Lever
- H. Throttle Control

### A.,G. Brake Levers

There are two hand operated brake levers, one located on the right handlebar and another located on the left handlebar. When squeezed, the right brake lever controls the front brake. The left brake lever controls the rear brake. When braking, the throttle should be in the neutral position.

**CAUTION:** If you apply the front or rear brake hard enough, it is possible to lock the wheels. This could cause you to lose control of the scooter. We suggest progressive use of the brakes to bring the scooter to a complete stop without locking the wheels. Your scooter is a lightweight performance product and therefore practice is recommended to safely perfect emergency stops.

### B. Flash-To-Pass

When the headlight is in the low beam position, push the flash-to-pass switch and the high beam will illuminate; it will stay illuminated until the switch is released. When released, this switch will default back to the low beam position; the high beam indicator will also illuminate.

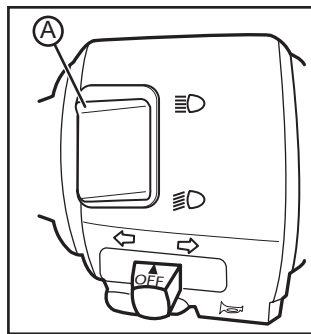

### C. Headlight High/Low Beam Switch

When the end of the switch (A) is pushed, the headlight will change from low beam to high beam. It will stay in the selected position until it is switched back. When in high beam position, the high beam indicator on the instrument cluster indicator display will illuminate.

The headlight system also has settable features. To set the features:

- Scooter must be in the system “ON” state.
- Cycling the key to “OFF” then to “ON” disables the feature.

### Dual Beam

- With the low beam selected, press switch down until you hear one horn beep.
- This can be done while moving or stationary.

## To Turn Lights Off in Daytime Running Light:

- The scooter must be stationary.
- With the low beam selected, press switch until you hear two (2) horn beeps.
- Position light will remain ON.

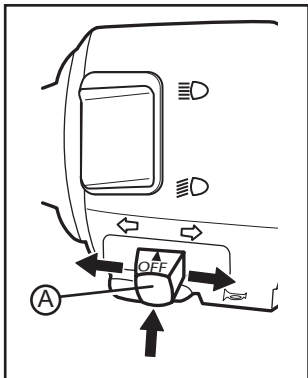

D. Turn Signal Switch  
When the turn signal switch (A) is moved in the left or right position, the corresponding front and rear turn signals will flash. When the turn signal switch is ON, the corresponding turn signal indicator on the instrument cluster indicator display will illuminate.

An audible signal will sound if the switch is left ON for 20 seconds or more while moving.

Always signal your turns and other maneuvers as required by law.

Unlike an automobile, the turn signals must always be cancelled manually on the scooter. Push in on the switch and it will return to the center, or, OFF position.

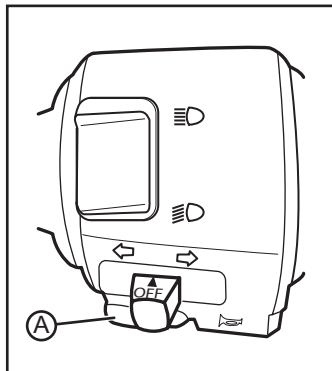

E. Horn Button  
When the key is in the ON position, the horn will sound when the button (A) is pressed. Electric vehicles run quietly; the horn can be used to warn pedestrians or other motorists of your presence. The horn's chirp feature allows you to send a "short" horn sound to alert pedestrians you are coming.



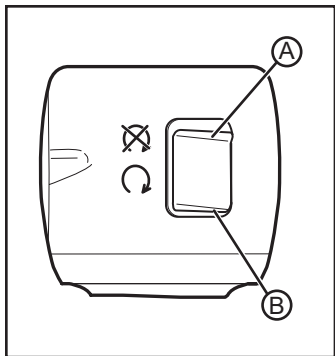

#### F. Power ON/OFF Switch

When the red switch is pressed up (A), it will stop power to the motor. The motor will remain in this state until the switch is pressed down (B). The switch does not turn off all electrical circuits, just the operation of the motor. This switch is a fast, convenient method of

shutting down the scooter in an emergency or under normal operation.

#### H. Throttle Control

Twist the throttle in a counter-clockwise (backward) rotation (A) to energize the motor and start the scooter in a forward direction. Release the throttle and it will snap back to the neutral position, de-energizing the motor.

When the scooter is moving, twisting the throttle control in a clockwise rotation (B) will engage the regen braking feature. Use regen braking, whenever safely possible, to increase your range. Regen braking takes some of the energy from the moving scooter and turns it back into electrical energy. This energy is then transferred to the battery, contributing to increased energy efficiency. A slight drag is felt when regen braking is activated.

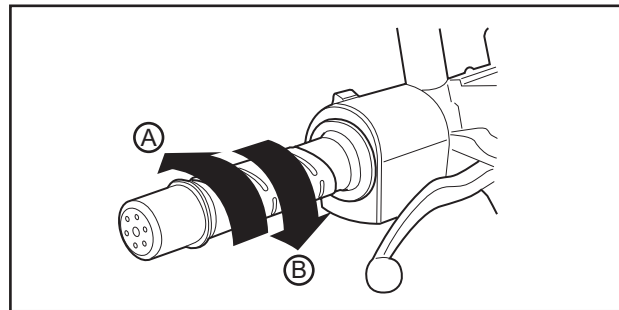

Your scooter has the ability to reverse at very low speeds to assist you with maneuvers such as backing out of parking spaces. Reverse is only enabled when the scooter is completely stopped. The VX-1 will reverse at a slow speed of 3 km/h (2 mph).

To activate reverse from a complete stop, return the throttle to the neutral position.

By requiring that the throttle returns to neutral before going into reverse, the VX-1 is prevented from going into reverse immediately after using regen braking to stop. Release the throttle control and the reverse drive ceases.

## General Operation

### Pre-Ride Inspection

Before operating the Vectrix VX-1, check the following to make sure the scooter is secure and intact:

- **Battery**

Make sure the battery level indicator display on the right instrument cluster is indicating a charged battery. The scooter should be charged if less than four (4) bars are showing.

- **Brakes**

Squeeze the brake levers individually while pushing the scooter to see if it rolls. You should be able to lock-up the wheels completely by applying the brakes.

Ensure that there is sufficient brake fluid in the master cylinder reservoir, and that there are no brake fluid leaks.

- **Throttle**

With the key switch in the OFF position, apply the throttle and release to verify that the throttle is smooth and returns correctly.

- **Steering**

Ensure that the steering movement is smooth and tight.

- **Tires**

Check both tires for condition and tread depth. Check cold tire pressure frequently. Maintain correct tire pressure as specified on page 5-6. Replace the tires when the tread height is 2/32" or less.

**CAUTION:** Under-inflation is the most common cause of tire failure and may result in severe tire cracking, tread separation, "blowout," or unexpected loss of scooter control, causing personal injury and possible death.

- **Electrical System**  
Check for correct function of the headlight, turn signals, and the brake/tail light.
- **Horn**  
Check for correct operation of the horn.

## Key Switch/Steering Lock Positions

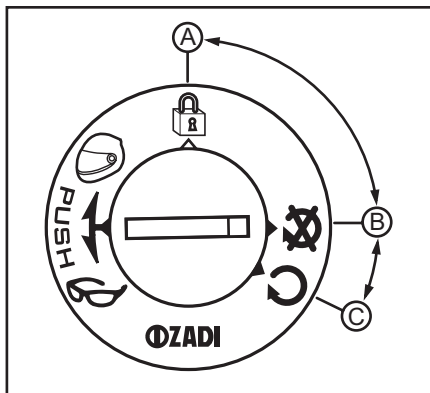

This is a five (5) position switch that is located in the center of the scooter in front of the step-through. There are three (3) operational positions and two (2) storage positions. The switch operational positions are as follows:

- A. Steering Lock
- B. OFF
- C. ON

The key should be removed from the scooter when parked to prevent theft. The key can be removed in either the OFF or steering lock position.

#### A. Steering Lock

Using the steering lock when parked will prevent unauthorized use and help prevent theft.

To Lock:

1. Turn the handlebar all the way to the left.
2. Turn the key counter-clockwise from the OFF position.
3. Remove the key.

To Unlock:

1. Install the key and turn clockwise to the OFF position.
2. Remove the key.

#### B. OFF

In this position:

- All functions are OFF
- Steering fork lock is not engaged
- Scooter can be moved

#### C. ON

In this position:

- All functions are ready
- Scooter can be enabled (ready to ride)
- Speedometer display turns ON
- Lights turn ON

## Key Switch/Storage Positions

There are two lockable storage compartments on the scooter. One is the trunk located under the seat and the other is the glove compartment located under the left side of the handlebar on the front of the step through panel.

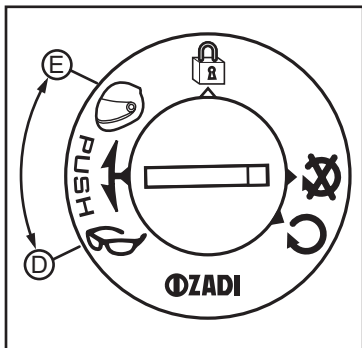

D. Glove  
Compartment

E. Trunk

## Storage Areas

**CAUTION:** Do not load the scooter any heavier than the gross vehicle weight rating (GVWR). Exceeding the GVWR could cause parts on the scooter to break, and could change the way in which the scooter handles. Either of these occurrences could cause you to lose control. Overloading can also shorten the life of the scooter.

- Make sure any luggage put on the scooter is firmly placed and secured.
- Do not overload your scooter.
- Do not attach items to the handlebars.
- Do not jam any items into any openings on the scooter. Doing so could cause loss of stability and potential harm to the rider.

E. Trunk

The trunk is an ideal location for helmet and cargo storage. The trunk also stores the AC charging cord. Carrying capacity of the trunk area is limited to 12 kg (26 lbs).

The trunk features an LED trunk light. This light is controlled by the seat. The light is ON anytime the seat is up, and turns OFF when the seat is fully closed.

### Opening the Trunk

**WARNING:** Do not attempt to open the trunk while someone is sitting on the seat. Possible damage to the latch assembly could result.

1. With the key switch in the OFF position, push down and turn the key clockwise.
2. Lift up on the front (A) of the rear seat.

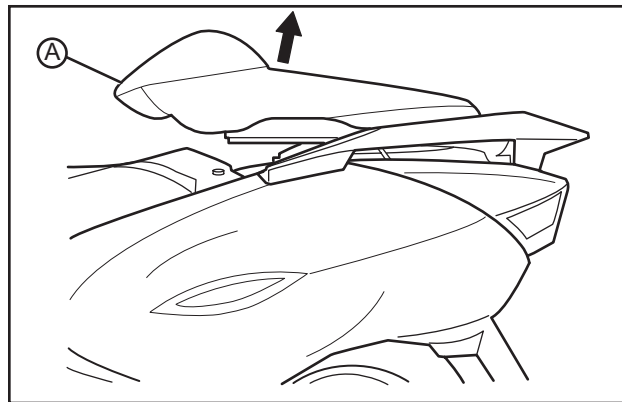

### Closing the Trunk

1. While holding on to the seat, push the middle of the seat support (B).
2. Lower the seat and push on the front until a click is heard, pull up on the seat to ensure that it is fully secured.

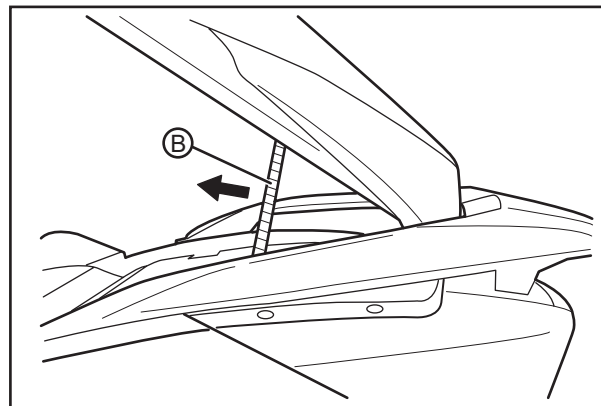

#### D. Glove Compartment

The carrying capacity of the glove compartment is limited to 2 kg (4 lbs).

To open the glove compartment, start with the key switch in the OFF position, push down and turn the key counter-clockwise. To close the glove compartment, close the door and push at the top until a click is heard.

#### Cargo Box (optional)

The carrying capacity of the cargo box is limited to 9 kg (20 lbs).

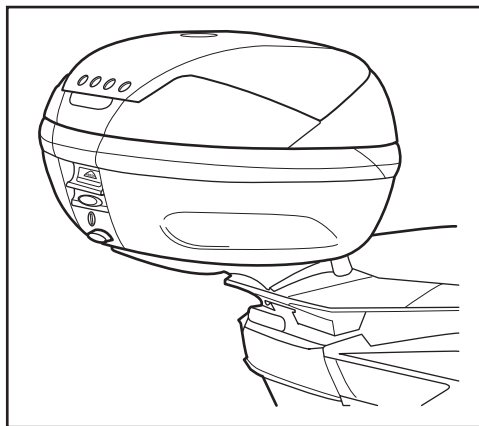



## Accessory Power Outlet

The accessory power outlet (A) is located inside the glove compartment. It is for charging of a 12 volt wireless phone. Lift the cover to access the outlet. Close the cover when not using the outlet. The device requirements should not exceed 0.5 amps (6 watts).

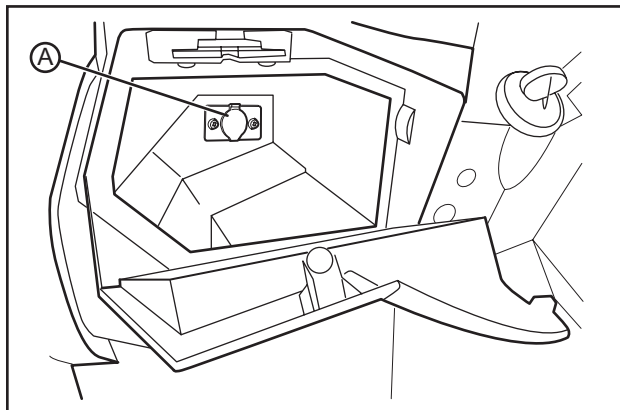

## Battery Charging

### CAUTION:

- Use extreme caution when dealing with electricity. Use residual current device (RCD) or ground fault circuit interrupter (GFCI) protected AC voltage outlet.
- DO NOT use non-grounded electrical plug adapters.
- DO NOT use the charging cord if any part of charging cord is damaged.

### WARNING:

- Do not use portable or stationary backup generating equipment to charge the scooter; this may damage the scooter's charging system. Only charge from a utility supplied voltage source. The appropriate AC voltage should be 120v/60Hz or 220v/50Hz.
- Vectrix does not advise the use of extension cords to charge the scooter. If you use an extension cord, it must be of the correct size to avoid excessive voltage drop. The extension cord should be rated for 20 amps and NO longer than 7.6 m (25 ft).

The battery charger is integrated into the scooter and monitors the status/condition of the battery pack during normal operation as well as charging. The battery pack is an integrated system of battery management as well as cooling air flow control. The charger will detect cell differences in the battery pack and automatically perform an Equalization Charge of the battery. You will be unaware of the action, except that charging time will be extended beyond the typical 3 to 5 hour charging time. The AC charging cord is located in the trunk storage area under the seat. The male connector on the charging cord is specific to the country.

It is recommended that you charge in a location that is away from combustible materials and in a well-ventilated area. If you are charging your scooter outdoors, avoid charging in the rain.

Frequent charging of the battery will significantly increase its life span, so do not hesitate to charge frequently. The charger's sensing electronics will stop/pause the charging process automatically. The charging process can be stopped at any time without damage.

During the charging process the instrument clusters will display several charge status items.

The left instrument cluster monitors the following:

- A. "Total Charge Time" displays the total charge time or time remaining during delay mode.
- B. "Highest Battery Temperature" displays, in sequence, the highest battery cell temperature in each of the four (4) modules, and the ambient temperature.
- C. "Battery Voltage" displays the system voltage while charging.

Display During Charging:

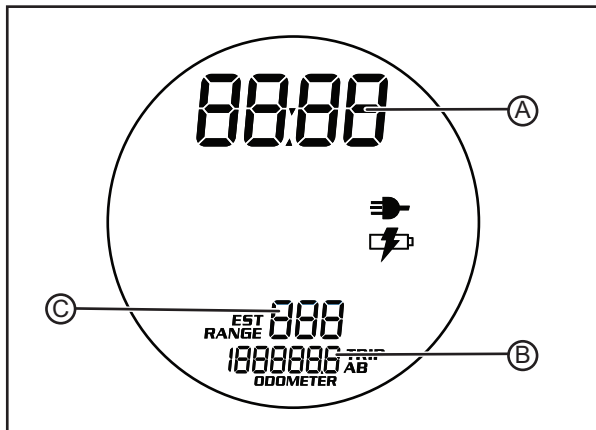

The center instrument cluster monitors the following:

D. The speedometer needle indicates the charge current times (X) 10 on the km/h scale (example 100 km/h indicates 10 amps).

E. The odometer field displays the charge mode and the voltage limit. The charge modes are:

“CC xx” = Constant current XXX is the target voltage.

“CV xx” = Constant Voltage.

“EC xx” = End of Charge and termination code.  
This indicates the reason for the termination (049 is normal).

“dE xx” = Delay mode.  
Cool down delay is active, the delay time remaining is shown on the left instrument cluster’s clock reading display xx is the target voltage.

It will also display high and low cell voltage (example High 3.45 Low 3.44).

Display During Charging:

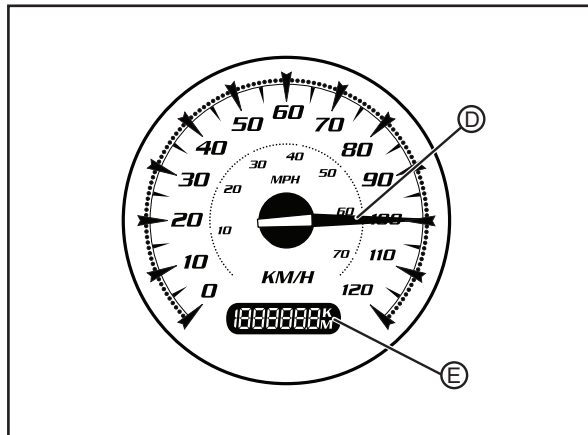

## Charging The Battery

If you have been running your scooter for a long period of time and the battery is hot, you should wait for it to cool down before charging. It takes longer to charge the battery when it is hot. The optimal temperature of the battery pack is 25°C (77°F). Depending on conditions, waiting 1 or 2 hours after riding before charging is sufficient.

1. Open the trunk. See opening the trunk on page 4-5.
2. Remove the cord, routing it through the designated locations (A) in the trunk edge. The trunk can now be closed during the charging process.

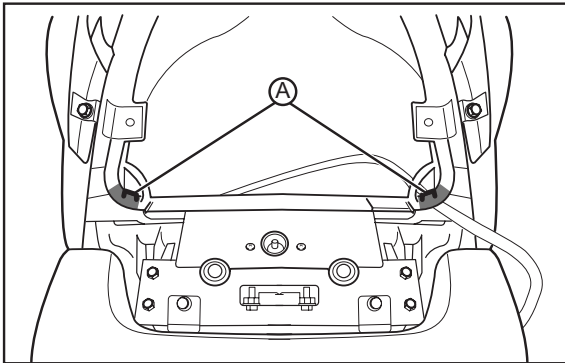

3. Plug the charger cord into the AC outlet. The onboard charger will automatically control the charging process.
4. As the battery charging continues, the right instrument cluster will display the level of charge (A), increasing as charging continues. When all bars of the display are illuminated, the battery is fully charged.

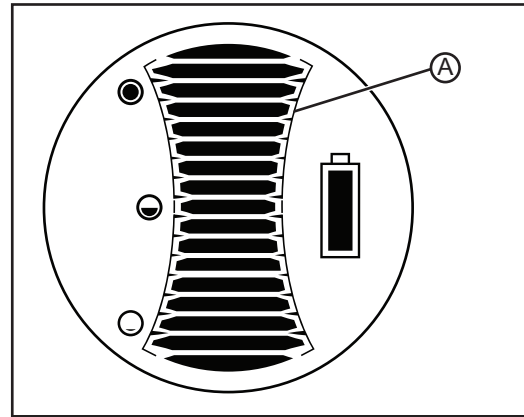

5. Upon completion of the charge, disconnect the charger cord from the AC power outlet and store the cord back into the trunk.

## Operating Your Scooter

### Starting

1. Verify that the charge level on the right instrument cluster is above 4 bars; if less than 4 bars, it is recommended that you charge your scooter.
2. Place the side stand or center stand, if equipped, in the up position.
3. Press the power ON/OFF switch to the ON position.
4. Turn the key switch to the ON position. When in the ON position, the instrument cluster and the malfunction indicators will illuminate. After a few moments the malfunction indicators should all turn off.

**WARNING:** If any malfunction indicator does not turn off, contact your authorized dealer. Operating with malfunction indicators on can cause permanent damage to your scooter.

5. With the key in the ON position the “READY” display (A) on the left instrument cluster should be on.

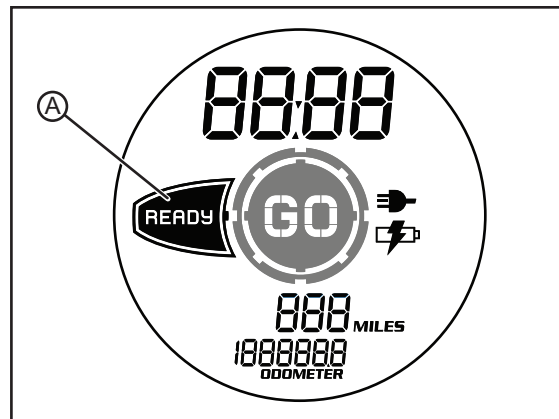

6. With the “READY” display on solid, squeeze and hold the left brake lever (B).

7. Then squeeze and release the right brake lever (C).

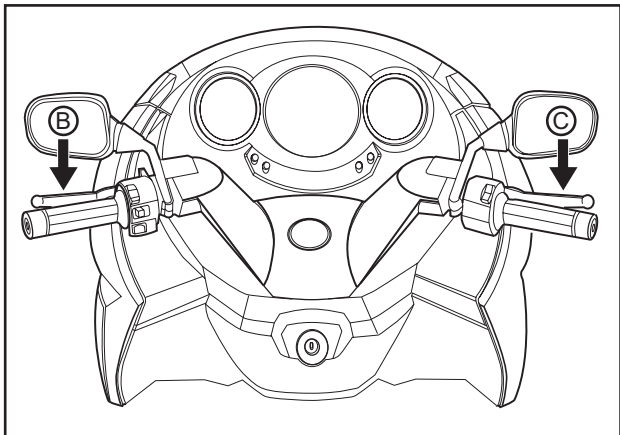

8. The “GO” display (D) should now be on/enabled.  
The scooter is now ready to go.

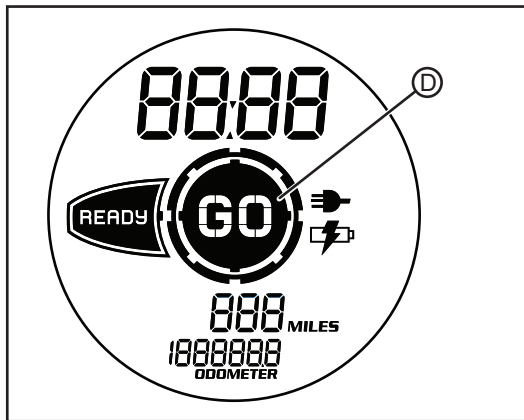

9. Twist the throttle toward you (counter-clockwise) to increase speed. When the throttle is twisted away from you (clockwise), the speed will decrease.

## Braking

On the right handlebar is the hand operated brake lever. This brake lever controls the front brake when the lever is squeezed. On the left handlebar is the hand operated brake lever that controls the rear brake. When braking, the throttle should be in the neutral position.

**CAUTION:** If you apply the front or rear brake hard enough, it is possible to lock the wheels. This could cause you to lose control of the scooter. We suggest progressive use of the brakes to bring the VX-1 scooter to a complete stop without locking the wheels. Your VX-1 scooter is a light-weight performance product and therefore practice is recommended to safely perfect emergency stops.

## Regenerative (Regen) Braking

A distinctive feature of your Vectrix scooter is the regenerative braking; this feature is part of the throttle control.

Coasting whenever possible makes a significant difference. The regen braking system on deceleration takes some of the energy from the motor and turns it back into electrical energy. This energy is transferred to the battery. Use the regen braking whenever safely possible to increase your range.

## Throttle Control

The throttle on the right handlebar is a distinctive feature of your scooter. The throttle is the user interface which determines forward motion as well as implementing regen braking and the reverse feature. The bi-directional throttle is very simple to use.

- Twist the throttle counter-clockwise to accelerate in the forward direction.
- Release the throttle and it returns to a neutral position.

To activate regen braking:

1. Simply twist the throttle clockwise beyond the neutral position and you will progressively engage in regen braking.
- Always “cover” the front brake lever with the index and middle fingers of your right hand when using regen braking to slow the scooter. This will ensure that you are ready to apply the front brake if it becomes necessary to slow the scooter quickly.

- Never use the rear brake lever (on the left handlebar) by itself or with regen braking without also using the front brake lever (on the right handlebar). Using only the rear brake may result in the rear tire sliding, particularly when regen is used. Be ready to apply both the front and rear brakes.

Your scooter has the ability to reverse at very low speeds to assist you with maneuvers such as backing out of parking spaces. Reverse is only enabled when the scooter is completely stopped.

The VX-1 will reverse at a slow speed of 3 km/h (2 mph). To activate reverse from a complete stop, return the throttle to the neutral position.

By requiring that the throttle returns to neutral before negotiating reverse, the VX-1 is prevented from going into reverse immediately after using regen braking to stop. Release the throttle and the reverse drive ceases.

## Stopping

1. With the throttle in the neutral position, press the power ON/OFF switch to the OFF position. This switch can also be used in an emergency to shut off the motor.
2. Turn the key switch to the OFF position and remove the key. To prevent theft, the key should be removed anytime the scooter is left unattended.
3. Be sure to charge the battery after each ride. See [Charging The Battery](#) on page 4-10.



## Rear Shock Adjustment

The rear shocks are equipped with a spring preload adjustment. This allows the spring preload to be adjusted for rider comfort and payload.

SPRING PRELOAD SETTINGS:	
Shortest Step (soft)	1
Longest Step (hard)	5

### Spring Pre-load Adjustment

1. Clean any dirt or debris from the shock near the adjustment ring (A).  
The adjustment ring is located on the lower portion of each rear shock.

**CAUTION:** Always adjust both shock springs' pre-load equally; otherwise, poor handling and loss of control may result.

2. Using a commercially available spanner wrench, adjust the spring preload. Decrease the pre-load on the spring by turning the spring adjuster to the shortest step on the shock. Increase the pre-load on the spring by turning the adjuster to the longest step on the shock.

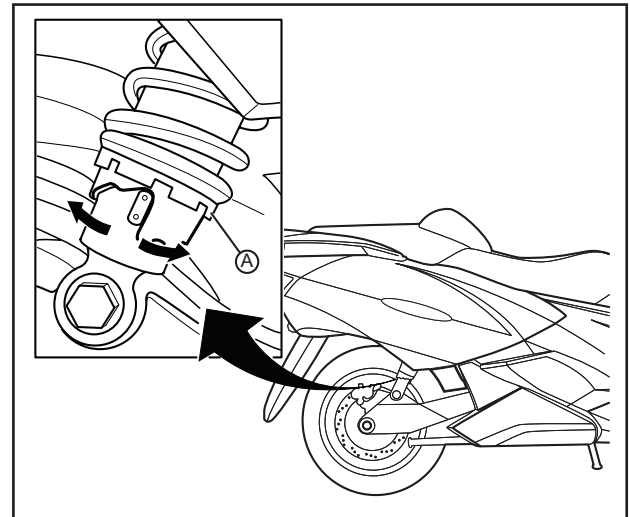

## Center Stand (optional)

The center stand (A) holds the scooter in an upright position.

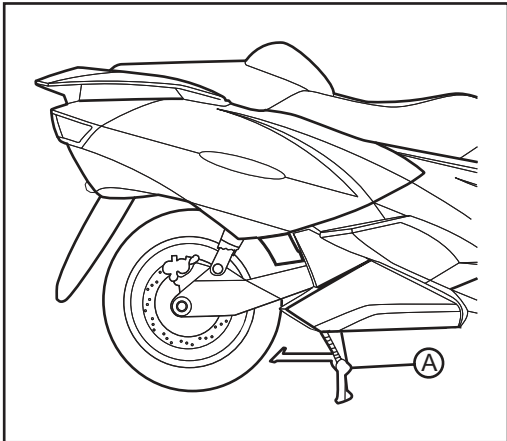

When to use the center stand:

- During a long stop
- When the ground or surface is too unstable for the side stand
- During servicing

Placing the VX-1 on the center stand:

1. Grasp the left side of the passenger grab handle with your right hand.
2. Hold the scooter level with your left hand on the left handlebar grip.
3. Place your right foot on the lower edge of the center stand and push downward while guiding the scooter backward.

To retract the center stand:

1. Straddle scooter.
2. Move scooter forward until center stand folds upward, back into the chassis.

## Side Stand

### CAUTION:

- The side stand must be in the upright position in order to safely operate the scooter. Failure to move the stand up could result in injury, and damage the scooter. There is an interlock which prevents the scooter from being enabled unless the side stand is in the up position.
  
- Do not sit on the scooter while the side stand is down. This could cause the side stand to sink into the ground resulting in injury, and damage to the scooter.

The side stand is located on the left side of the scooter. Park only on level hard surfaces. Avoid parking on hills or unstable ground.

Always check the ground before putting the side stand down to ensure that it is stable. Hot temperatures can cause the stand to sink into the pavement, so it is recommended to have a small metal plate for the stand to rest on in high heat.

An indicator on the instrument cluster indicator display will illuminate when the side stand is down.

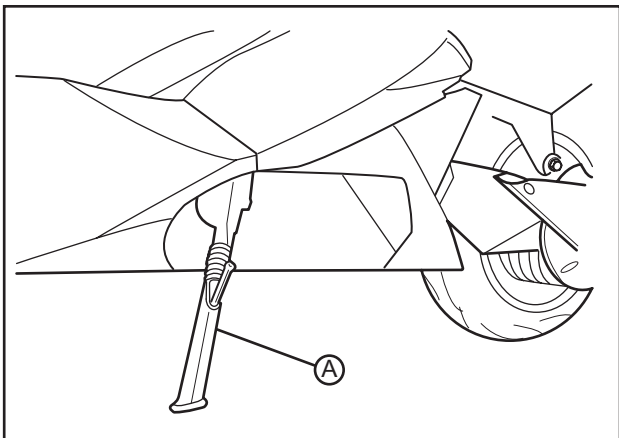

Placing the VX-1 on the side stand:

1. Set the scooter on a firm surface.
2. Fold out the side stand (A) with the left foot using the side stand bar until it snaps into place.

To fold the side stand in:

1. Straddle the scooter.
2. Set the scooter upright.
3. Use your left foot to return side stand upward into the chassis.

**Note:** When the side stand is out and the key is in the “ON” position, the throttle is disabled.

## Owner's Responsibilities

1. This owner's manual should be considered a permanent part of this scooter and should remain with it even if the scooter is subsequently sold.
2. Perform routine care and maintenance on your electric scooter as detailed in this owner's manual.
3. Use only Vectrix approved parts and Vectrix scooter accessories.
4. The operator is responsible for learning and obeying all country, federal, state, and local laws governing the operations of an electric scooter.
5. Always wear a regionally approved helmet, goggles, appropriate boots, and all other appropriate safety equipment when operating an electric scooter.

## Battery

**WARNING:** You must leave your scooter on the charger if you expect it to sit in storage or unused for more than one (1) month.

Please leave your Vectrix scooter plugged in whenever possible.

1. The battery is a Lithium-Ion Phosphate system. While it does require charging, it does not require maintenance.
2. The battery should be kept away from excessive heat. The silicon/lead cells should not get above 71°C (160°F). Do not store in a hot trailer.
3. Only your authorized Vectrix dealer is qualified to have access to and troubleshoot the battery.
4. Dispose of the battery according to your state and local laws.

## General Maintenance

### Brakes

#### Brake Fluid Level Inspection

**WARNING:** Do not spill brake fluid on painted surfaces, the finish could be damaged. Spilling brake fluid on the body plastics will cause them to crack. Clean off any brake fluid spills immediately.

Always place a shop towel under the master cylinder reservoir prior to removing cover.

Low fluid levels may indicate worn brake pads or a leak in the hydraulic system. Inspect the brake pads for wear and/or the hydraulic system for leaks. Use only new DOT 4 brake fluid from a sealed container.

The brake fluid should be flushed out and replaced every two (2) years.

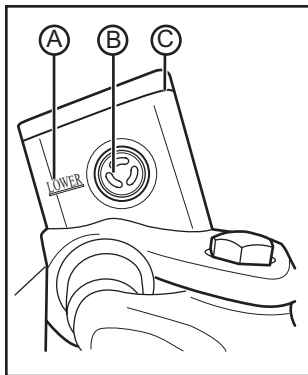

Inspect the level of the brake fluid through the sight glass (B). If the fluid level is visibly below the low level indicator (A), brake fluid must be added. Clean any dirt or debris from the cover (C) before opening the reservoir.

1. Remove the two Phillips screws securing the cover onto the reservoir, and remove the cover.
2. Add new DOT 4 brake fluid.
3. Inspect the cover seal, ensuring that it is free of any wear or damage and that it is positioned correctly.
4. Install the cover and tighten the Phillips screws.

## Brake Pad Wear Inspection

The front and rear brake pads should be inspected regularly for wear. Visually inspect the brake pads by looking at the remaining friction material through the sides of the brake calipers. If either the front or rear brake pads are found to be worn, contact your authorized Vectrix dealer. Do not drive your scooter with worn brake pads as this can cause your brakes to fail resulting in an accident.

### Front Brake Pads:

The front brake pads have a wear indicator (A) built into the friction material of the pads. When this indicator is no longer visible, the brake pads are worn and need to be replaced.

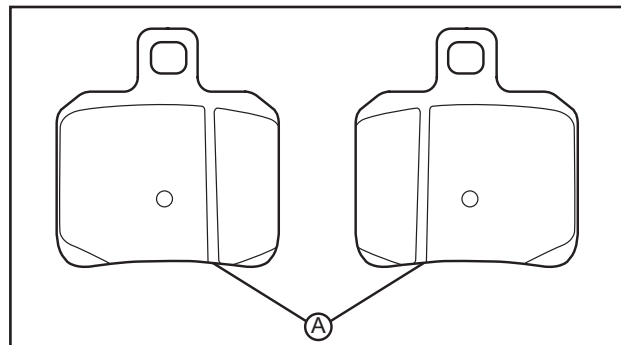

## Rear Brake Pads:

The rear brake pads should be replaced when there is 1 mm (.04 in) friction material remaining.

## Gearbox Vent

The gearbox vent (A) is located on the top of the motor side (left) swingarm. This vent should be kept clean of dirt and debris.

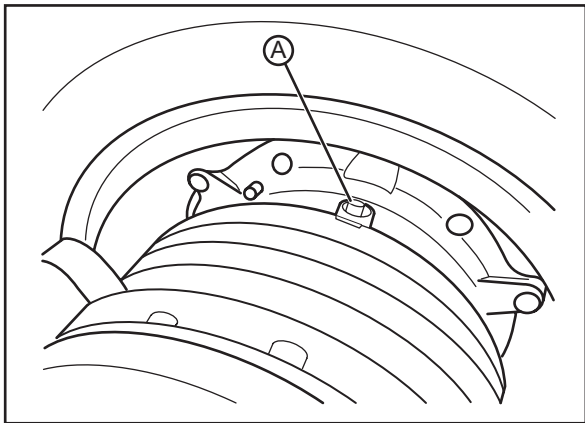

## Suspension

### Front

- Visually inspect the front fork seals for any leakage.
- Visually inspect for scratches or damage on the inner front fork tubes.

### Rear

**CAUTION:** The shock absorber assembly contains highly pressurized gas.

- Do not attempt to tamper with or open the shock.
- Do not subject the shock to high temperature or open flame.

**Doing either of these can cause the shock to rupture causing personal injury or death.**



## Wheels And Tires

Inspect both wheels for the following:

- Bent or cracked rims
- Impact marks on the rims

Inspect both tires for the following:

- Cuts, cracks, splits, or missing tread lugs in the tread or sidewall area
- Bumps or bulges within the tire body
- Uneven tire tread wear. Wear on one side of the tire tread or flat spots in the tire tread indicate a problem with the tire or scooter.
- Exposed tire thread or cords
- Worn Tire Thread. See Tire Wear Indicators (TWI) on page 5-6.

If either of the wheels or tires are found to have any of the aforementioned conditions, replace the wheel and tire immediately.

**CAUTION:** You must replace tires with the standard size recommended. Avoid tires that are larger than recommended. Failure to do so could result in injury or death.

## Replacement Tire Size

Replacement tires must be of the same size and meet or exceed the load and specification capability of the original tires.

- Front Pirelli GTS23 120/70-14
- Rear Pirelli GTS24 140/60-13

## Tire Wear Indicators (TWI)

TWI indicators are marked in various locations around the side wall of the tire.

TWI (wear bars) are located at the base of the main grooves and are equally spaced around the tire. Always replace the tires when they reach a remaining tread depth of two thirty-seconds of an inch (2/32"). If not corrected, wet weather accidents are more likely to occur due to skidding on bald or nearly bald tires. Also, excessively worn tires are more susceptible to damage from road hazards. Built-in tread wear indicators (A), or "wear bars," which look like narrow strips of smooth rubber across the tread, will appear on the tire when that point of wear is reached. When you see these wear bars, the tire is worn out and it's time to replace.

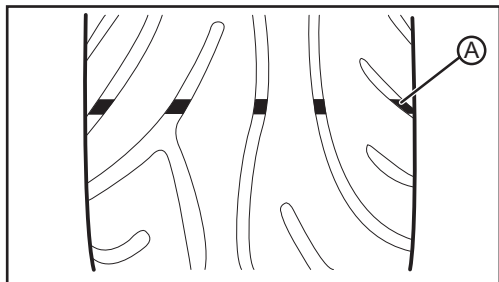

## Tire Inflation

**CAUTION:** Under-inflation is the most common cause of tire failure and may result in severe tire cracking, tread separation, "blowout," or unexpected loss of scooter control causing personal injury and possible death.

Riding on tires that are low can result in decreased range and performance.

Tire pressure should be checked and adjusted before each ride. Tire pressure is checked using an accurate gauge when the tires are cold. This means that the tires have not been ridden on for 3 hours. Always replace the valve stem cap when finished.

FRONT	REAR
220 kpa (32 psi)	276 kpa (40 psi)

## Lights

Because body panels need to be removed, all lights must be changed by an authorized Vectrix dealer.

## Cleaning

To prolong the life of your scooter it should be washed periodically. Regular cleaning, using correct methods, is an important factor in maintaining the value of your scooter. It also ensures that safety-relevant parts remain in full working order.

**CAUTION:** After cleaning and before starting your journey, always test the brakes.

A scooter that is constantly parked outdoors must be covered with a protective covering in order to prevent weathering of painted panels and to prevent cracking of seats and other plastic parts.

If tar, bugs, or other similar deposits have accumulated, wash them off as soon as possible. Do not use an insect sponge as this can result in scratches. Do not use high pressure or steam cleaners; they can cause water intrusion of bearing, seals, and electrical components. Avoid spraying water of great force around the instrument clusters, key switch and master cylinders. Avoid using strong acidic wheel cleaners. If such products are used on hard-to-remove dirt, do not leave the cleaner on the affected area any longer than instructed.

Also, thoroughly rinse the area off with water, immediately dry it, and then apply a corrosion protection spray.

**WARNING:** Improper cleaning can damage electrical components, cowlings, panels, and other plastic parts. Use only a soft, clean cloth or sponge with mild detergent and water to clean plastic.

Check for damage to painted surfaces. If any damage is found, repair the surface with touch up paint.

## Windshield

Clean the windshield with a soft cloth and warm water, with a mild detergent. If scratched, polish with a commercially available plastic polish. Replace the windshield if it becomes scratched or discolored enough to obstruct your view.

Do not use any harsh chemical products on plastic parts. Be sure to avoid using cloths or sponges which have been in contact with strong abrasive cleaning products, solvent or thinner, fuel (gasoline), rust removers or inhibitors, brake fluid, antifreeze or electrolyte.

After gently washing the scooter, be sure to allow all of the electrical components to dry prior to operation. If the scooter is ridden immediately after being washed, apply both brakes several times in order to remove any moisture from the brake pads. Do not use products such as tire dressings on tires as this will deteriorate traction.

## Parking And Long Term Storage

1. It is recommended to always leave the battery on the charger when in long term storage. The Vectrix VX-1 charger is designed to maintain a balanced and complete charge at all times without wasting any energy.
2. To prolong the life of your battery you should store your scooter in a cool area. Storing your scooter in a hot area will cause your battery's life to be shortened.
3. If, for some reason, your scooter was not plugged in for several days, you should always charge it up before riding.

For more information on the battery and the electrical system see Battery Charging on page 4-7.

**CAUTION:** Opening the battery is for your authorized Vectrix dealer only. Please be aware that incorrect handling of a Vectrix battery can be dangerous.  
**DO NOT OPEN!**

## Dealer Inspection 483 km (300 mile)

This inspection is very important and must be performed in a time period that is as close to 483 km (300 miles) as possible but not in excess of 563 km (350 miles), and no longer than one year from the date of delivery.

- Charge Batteries (note Battery Guidelines) and check contacts
- Check Tire Pressure and correct if necessary
- Check all Main Screws for the stipulated torque
- Check Screws, Nuts, and Fastening Points

- Check the functioning of the Front and Rear-wheel Suspension
- Check that all working parts are in operating order
- Check Lights/Headlight setting
- Check Directional Stability, Front and Rear Brakes, and handling

483 km (300 mile) Inspection

Performed at Mileage: \_\_\_\_\_

Date/Signature/Stamp **VECTRIX** Dealer

## Maintenance Schedule

The scheduled maintenance must be performed every 3000 km (1,864 mi) or 12 months in accordance with this chart to keep the Vectrix VX-1 scooter in top running condition. The initial maintenance is vitally important and must not be neglected.

NO.	ITEM	Routine
1	Front Brake	Check operation, and for fluid leakage. Replace brake pads if necessary.
2	Rear Brake	Check operation, and for fluid leakage. Replace brake pads if necessary.
3	Brake Hose	Check for cracks or damage. Replace if necessary.
4	Wheels	Check runout, and for damage. Replace if necessary.
5	Tires	<ul style="list-style-type: none"><li>• Check tread depth, and for damage. Replace if necessary.</li><li>• Check air pressure. See page 5-6. Correct if necessary.</li></ul>
6	Wheel Bearings	Check bearings for smooth operation. Replace if necessary.
7	Steering Bearings	Check bearing assembly for looseness.
8	Chassis Fasteners	Check all chassis fittings and fasteners. Correct if necessary.
9	Front/Rear Brake Lever Pivot Shaft	Apply silicon grease lightly.
10	Front Fork/Suspension	Check operation and for oil leakage.

NO.	ITEM	Routine
11	Rear Shock Absorber Assembly/Suspension	<ul style="list-style-type: none"> <li>• Check operation and for oil leakage.</li> <li>Replace if necessary.</li> </ul>
12	Throttle Grip	Check operation and free play.
13	Kickstand Pivots	<ul style="list-style-type: none"> <li>• Check operation.</li> <li>• Apply silicon grease lightly.</li> </ul>
14	Centerstand Pivots	Check operation.
15	Lights	<ul style="list-style-type: none"> <li>• Check operation of all lights.</li> <li>• Check headlight setting.</li> </ul>
16	Batteries	Charge battery. See Charging the Battery on page 4-10.

## Vectrix Scooter Accessories

Vectrix accessories are designed to complement and function with other systems on your scooter. Your authorized Vectrix dealer can accessorize the scooter using genuine Vectrix accessories.

VX-1 Routine Maintenance Record

DATE OF SERVICE	MILEAGE	SERVICE DESCRIPTION	COMMENTS



All of the scooters are carefully inspected before they are delivered. However, even after the scooters are inspected, some technical issues can occur. The following information offers a guide to help you to identify an issue, and if possible, repair it yourself. If you are unable to solve an issue with your Vectrix scooter, take it to an authorized Vectrix dealer at your convenience. If there is no dealer in your area email Vectrix at [service@vectrix.com](mailto:service@vectrix.com).

## Troubleshooting

For the topics described here, we assume that only the components are the cause of the malfunction. If the fault still occurs after the component(s) have been replaced, then it is necessary to visit your authorized dealer.

### Brakes

Squealing noises while braking indicate worn brake pads or that there is a foreign object (e.g. a stone/pebble/rock) in the brakes. If any abnormal brake noises are heard, contact your authorized Vectrix dealer as soon as possible.

### Tires

Tire pressure can be checked and adjusted if necessary at any service station.

- Front tire normal air pressure is 32 psi (220 kpa)
- Rear tire normal air pressure is 40 psi (276 kpa)

**Note:** Low air pressure can result in decreased range. Always check tire pressure to keep at optimal performance. Worn tires will affect handling and range!

**CAUTION:** You should replace VX-1 tires with the standard sizes recommended. Avoid tires that are larger than the recommended size. Failure to do so could result in injury or death. See Replacement Tire Size on page 5-5.

## General Troubleshooting

SYMPTOM	POTENTIAL CAUSE	POTENTIAL SOLUTION
Scooter does not turn on	Key not properly engaged	Recheck key in switch, turn OFF/ON again
Scooter ON but no 'ready' light	Power ON/OFF switch not engaged	Recheck switch, turn OFF/ON
	Scooter plugged into AC	Unplug scooter
	Throttle not set	Call Vectrix authorized dealer for instructions
Ready light flashing	Side stand switch not engaged	Check stands/deploys and retract/check connection
Charger not working	AC power missing	Check AC outlet for power, AC source check fuse/voltage
Premature charge termination	Charger and battery un-synchronized	Run scooter until battery icon blinks and fuel gauge resets to '0' and charge scooter.
	Charger firmware out of date	Contact your authorized Vectrix dealer. Technician must determine charger firmware revision and update minimum Rev 2012, or thereafter.

## General Troubleshooting, cont'd

SYMPTOM	POTENTIAL CAUSE	POTENTIAL SOLUTION
Handlebars wobbly (shimmy)	Tire pressure	Inflate to correct tire pressure. See Tire inflation on page 5-6
	Deformed front tire	Replace/balance front tire with the same tire supplied from the factory. See Replacement Tire Size on page 5-5.
	Bald tire (excess wear)	Replace/balance tire with the same tire supplied from the factory. See Replacement Tire Size on page 5-5.
	Cargo box installed	Check the scooter's behavior without cargo box. Never exceed the maximum load allowed in the cargo box. See Storage Area for more information.



## Customer Assistance

Vectrix can be contacted via the contact methods listed below. Please have the following available as they are essential to effectively and efficiently answer your questions or resolve your concerns.

- Owner's name and address
- Owner's telephone number
- Vehicle identification number (VIN)
- Date of purchase
- Motor serial number

An owner information chart is provided on page 1-3 to record this information.

## Vectrix USA

Corporate Office:  
55 Samuel Barnet Blvd.  
New Bedford, MA 02745  
Phone: 508-717-6510  
FAX: 508-721-6846

Sales:  
11235 West Bernardo Ct.  
San Diego, CA 92127  
Phone: 508-717-6511  
FAX: 508-721-6846

## Vectrix International

Vectrix Sp. Z O.O.  
ul. Magazynowa 7  
55-040 Bielany Wroclawskie  
Poland  
Phone: +48-71-710-8420

## USA Email

General:..... info@vectrix.com  
Fleet:..... fleet@vectrix.com  
Media:..... media@vectrix.com  
Marketing:..... marketing@vectrix.com  
Service:..... service@vectrix.com  
Sales:..... sales@vectrix.com

## Warranty Information

### Warranty Registration

- Refer to the Vectrix dealer to register your VX-1 scooter with Vectrix at time of sale.
  - Failure to do so may result in Warranty claims being delayed or not paid.
- Liability for Warranty cases is determined by the legal regulations beginning at the time of delivery to the end user (two years).
- Defects that are not reported to an authorized Vectrix dealer within the above time period are not subject to Warranty claims.
- Vectrix, LLC and its appointed dealer shall decide whether faulty parts will be replaced or repaired.

- Warranty is voided when:
  - ♦ The end user has treated the VX-1 contrary to regulations, especially by overloading the vehicle.
  - ♦ The end user has even one of the VX-1 inspections outlined in the Customer Service book or a repair performed by a workshop or repair facility that is not authorized by Vectrix.
  - ♦ The VX-1 operating, maintenance, and service instructions outlined in this manual have not been followed.
  - ♦ The end user neglects the battery charging procedure outlined in Chapter 4 Page 7 “Charging the Battery.”
- The following are excluded from the Warranty:
  - ♦ Light Bulbs
  - ♦ Brake Pads and Brake Discs
  - ♦ Tires
  - ♦ Accessories not part of Standard Equipment

## **FOR USA Vehicles Only**

### **Safety Defects**

Contact the National Highway Safety Traffic Administration (NHSTA) if you believe that this vehicle has a defect that could cause an accident, injury, or death. Also, contact Vectrix, LLC immediately. If the NHSTA receives multiple complaints, it will lead an investigation. The NHSTA may opt to recall vehicles if it perceives a safety threat. The NHSTA cannot deal with individual problems with dealerships of Vectrix, LLC.

The NHSTA can be reached at  
1-800-4848-9393  
or you can write them at:  
NHSTA  
U.S. Department of Transportation  
Washington, D.C. 20590





## A

- Accessories ..... 5-11
- An Important Message To You From Vectrix ..... 1-1

## B

- Battery ..... 4-1, 5-2
- Battery Charging ..... 4-7
- Brake Fluid Level Inspection ..... 5-2
- Brake Pad Wear Inspection ..... 5-3
- Brakes ..... 4-1, 5-2, 6-1
  - Brake Fluid Level Inspection ..... 5-2
  - Brake Pad Wear Inspection ..... 5-3
  - Gearbox Vent ..... 5-4
- Braking ..... 4-13

## C

- Cargo Box (optional) ..... 4-6
- Center Instrument Cluster ..... 3-9
- Center Stand (Optional) ..... 4-16
- Charging The Battery ..... 4-10

- Cleaning ..... 5-7
  - Windshield ..... 5-8
- Closing the Trunk ..... 4-5
- Controls and Components ..... 3-1
  - Center Instrument Cluster ..... 3-9
  - Front and Rear View ..... 3-4
  - Handlebar Controls ..... 3-16
  - Instrument Cluster Controls ..... 3-15
  - Instrument Cluster Indicator Display ..... 3-12
  - Left Instrument Cluster ..... 3-10
  - Main Components ..... 3-1
  - Right Instrument Cluster ..... 3-8
  - Scooter Controls and Gauges ..... 3-6
- Customer Assistance ..... 7-1

## D

- Dealer Inspection ..... 5-9

<b>E</b>	
Electrical System .....	4-2
Emissions Information .....	1-10

<b>F</b>	
Frequently Asked Questions.....	1-8
Front Suspension.....	5-4
Front and Rear View.....	3-4

<b>G</b>	
Gearbox Vent.....	5-4
General Information .....	1-5
Technical Specifications.....	1-5
General Maintenance.....	5-2
Brakes.....	5-2
Cleaning.....	5-7
Lights.....	5-6
Replacement Tire Size.....	5-5
Suspension .....	5-4
Tire Inflation.....	5-6
Tire Wear Indicators (TWI).....	5-6
Wheels And Tires .....	5-5

General Operation .....	4-1
Key Switch/Steering Lock Positions .....	4-2
Key Switch/Storage Positions .....	4-4
Pre-Ride Inspection .....	4-1
General Safety Precautions.....	2-1
General Troubleshooting.....	6-2
Glove Compartment.....	4-6

<b>H</b>	
Handlebar Controls .....	3-16
Horn.....	4-2

<b>I</b>	
Important Operating Information.....	2-2
Inspection .....	5-9
Instrument Cluster Controls.....	3-15
Instrument Cluster Indicator Display.....	3-12
Introduction.....	1-1

<b>K</b>	
Key Code Number.....	1-4
Key Switch/Steering Lock Positions.....	4-2

Key Switch/Storage Position .....	4-4
Cargo Box (optional) .....	4-6
Closing the Trunk .....	4-5
Glove Compartment.....	4-6
Opening the Trunk.....	4-5
Storage Areas.....	4-4

## L

Labels .....	2-3
Accessory Port Notice.....	2-6
Department of Transportation (DOT) Label.....	2-5
High Voltage Warning Label .....	2-7
Manufacturer's Data Plate.....	2-4
Side Stand Warning .....	2-7
Vehicle Identification Number (VIN).....	2-3
Left Instrument Cluster .....	3-10
Lights.....	5-6

## M

Main Components.....	3-1
Maintaining Your Scooter.....	5-1
Battery.....	5-2
Dealer Inspection.....	5-9

General Maintenance .....	5-2
Owner's Responsibilities .....	5-1
Parking And Long Term Storage .....	5-8
Vectrix Scooter Accessories.....	5-11
Maintenance Record.....	5-12
Maintenance Schedule .....	5-10
Motor Serial Number .....	1-4

## O

Opening the Trunk.....	4-5
Operating Information .....	2-2
Operating Your Scooter .....	4-11
Braking .....	4-13
Starting.....	4-11
Stopping.....	4-14
Throttle Control.....	4-13
Optimizing Your Range By Adapting Your Riding Style.....	1-10
Owner Information .....	1-3
Owner's Responsibilities.....	5-1

## P

Parking And Long Term Storage.....	5-8
Plug in Your Scooter's Battery.....	1-2
Pre-Ride Inspection .....	4-1
Battery.....	4-1
Brakes.....	4-1
Electrical System .....	4-2
Horn .....	4-2
Steering.....	4-1
Throttle .....	4-1
Tires .....	4-1

## R

Rear Shock Adjustment.....	4-15
Rear Suspension .....	5-4
Rear View.....	3-4
Regenerative Breaking .....	4-13
Replacement Tire Size .....	5-5
Right Instrument Cluster.....	3-8

## S

Safety Information.....	2-1
Scooter Controls and Gauges.....	3-6
Side Stand .....	4-17
Starting .....	4-11
Starting And Operating .....	4-1
Battery Charging.....	4-7
Charging The Battery .....	4-10
General Operation .....	4-1
Key Switch.....	4-2, 4-4
Operating Your Scooter.....	4-11
Pre-Ride Inspection .....	4-1
Steering Lock.....	4-2
Storage.....	4-4
Steering .....	4-1
Steering Lock Positions.....	4-2
Stopping .....	4-14
Storage Areas .....	4-4
Storage Position.....	4-4
Cargo Box (optional).....	4-6
Closing the Trunk .....	4-5
Glove Compartment.....	4-6
Opening the Trunk.....	4-5

Storage Areas.....	4-4
Suspension.....	5-4
Front.....	5-4
Rear .....	5-4

## **T**

Technical Specifications.....	1-5
Throttle Control .....	4-1, 4-13
Tire Inflation .....	5-6
Tire Wear Indicators (TWI).....	5-6
Tires.....	4-1, 5-5, 6-1
Transporting .....	1-11
Front.....	1-11
Left Side.....	1-11
Rear .....	1-11
Right Side .....	1-12
Troubleshooting.....	6-1
Brakes .....	6-1
General Troubleshooting .....	6-2
Tires .....	6-1
Trunk .....	4-4

## **U**

Useful Information For Safe Riding .....	1-2
--	-----

## **V**

Vehicle Identification Number/(VIN) Location .....	2-3, 1-4
Vehicle Range.....	1-8

## **W**

Warranty Information.....	7-2
Warranty Registration .....	7-2
Warranty/Customer Assistance.....	7-1
Wheels And Tires.....	5-5

